

# Cinterion<sup>®</sup> BGS5

Hardware Interface Description

Version: 01.100  
DocId: BGS5\_HID\_v01.100



Document Name: **Cinterion® BGS5 Hardware Interface Description**

Version: **01.100**

Date: **2013-11-21**

DocId: **BGS5\_HID\_v01.100**

Status **Confidential / Released**

**GENERAL NOTE**

THE USE OF THE PRODUCT INCLUDING THE SOFTWARE AND DOCUMENTATION (THE "PRODUCT") IS SUBJECT TO THE RELEASE NOTE PROVIDED TOGETHER WITH PRODUCT. IN ANY EVENT THE PROVISIONS OF THE RELEASE NOTE SHALL PREVAIL. THIS DOCUMENT CONTAINS INFORMATION ON GEMALTO M2M PRODUCTS. THE SPECIFICATIONS IN THIS DOCUMENT ARE SUBJECT TO CHANGE AT GEMALTO M2M'S DISCRETION. GEMALTO M2M GMBH GRANTS A NON-EXCLUSIVE RIGHT TO USE THE PRODUCT. THE RECIPIENT SHALL NOT TRANSFER, COPY, MODIFY, TRANSLATE, REVERSE ENGINEER, CREATE DERIVATIVE WORKS; DISASSEMBLE OR DECOMPILE THE PRODUCT OR OTHERWISE USE THE PRODUCT EXCEPT AS SPECIFICALLY AUTHORIZED. THE PRODUCT AND THIS DOCUMENT ARE PROVIDED ON AN "AS IS" BASIS ONLY AND MAY CONTAIN DEFICIENCIES OR INADEQUACIES. TO THE MAXIMUM EXTENT PERMITTED BY APPLICABLE LAW, GEMALTO M2M GMBH DISCLAIMS ALL WARRANTIES AND LIABILITIES. THE RECIPIENT UNDERTAKES FOR AN UNLIMITED PERIOD OF TIME TO OBSERVE SECRECY REGARDING ANY INFORMATION AND DATA PROVIDED TO HIM IN THE CONTEXT OF THE DELIVERY OF THE PRODUCT. THIS GENERAL NOTE SHALL BE GOVERNED AND CONSTRUED ACCORDING TO GERMAN LAW.

**Copyright**

Transmittal, reproduction, dissemination and/or editing of this document as well as utilization of its contents and communication thereof to others without express authorization are prohibited. Offenders will be held liable for payment of damages. All rights created by patent grant or registration of a utility model or design patent are reserved.

Copyright © 2013, Gemalto M2M GmbH, a Gemalto Company

**Trademark Notice**

Gemalto, the Gemalto logo, are trademarks and service marks of Gemalto and are registered in certain countries. Microsoft and Windows are either registered trademarks or trademarks of Microsoft Corporation in the United States and/or other countries. All other registered trademarks or trademarks mentioned in this document are property of their respective owners.

## Contents

<b>1</b>	<b>Introduction .....</b>	<b>9</b>
1.1	Key Features at a Glance .....	9
1.2	BGS5 System Overview .....	12
1.3	Circuit Concept .....	13
<b>2</b>	<b>Interface Characteristics .....</b>	<b>14</b>
2.1	Application Interface .....	14
2.1.1	Pad Assignment.....	14
2.1.2	Signal Properties.....	16
2.1.2.1	Absolute Maximum Ratings .....	21
2.1.3	USB Interface.....	22
2.1.4	Serial Interface ASC0 .....	23
2.1.5	Serial Interface ASC1 .....	25
2.1.6	UICC/SIM/USIM Interface.....	27
2.1.6.1	Enhanced ESD Protection for SIM Interface.....	29
2.1.7	Digital Audio Interface.....	30
2.1.8	RTC Backup.....	32
2.1.9	GPIO Interface .....	33
2.1.10	I <sup>2</sup> C Interface .....	35
2.1.11	SPI Interface .....	37
2.1.12	PWM Interfaces .....	38
2.1.13	Pulse Counter .....	38
2.1.14	Control Signals.....	38
2.1.14.1	Status LED .....	38
2.1.14.2	Power Indication Circuit .....	39
2.1.14.3	Host Wakeup.....	39
2.1.14.4	Fast Shutdown .....	40
2.2	RF Antenna Interface.....	41
2.2.1	Antenna Interface Specifications .....	41
2.2.2	Antenna Installation .....	43
2.2.3	RF Line Routing Design.....	44
2.2.3.1	Line Arrangement Examples.....	44
2.2.3.2	Routing Example.....	45
2.3	Sample Application .....	46
2.3.1	Sample Level Conversion Circuit.....	48
<b>3</b>	<b>Operating Characteristics .....</b>	<b>49</b>
3.1	Operating Modes .....	49
3.2	Power Up/Power Down Scenarios.....	50
3.2.1	Turn on BGS5.....	50
3.2.1.1	Switch on BGS5 Using ON Signal .....	50
3.2.2	Restart BGS5.....	51
3.2.2.1	Restart BGS5 via AT+CFUN Command.....	51
3.2.2.2	Restart BGS5 Using EMERG_RST.....	52

---

3.2.3	Signal States after Startup .....	53
3.2.4	Turn off BGS5 .....	54
3.2.4.1	Switch off BGS5 Using AT Command .....	54
3.2.4.2	Disconnect BGS5 BATT+ Lines .....	55
3.2.5	Automatic Shutdown .....	56
3.2.5.1	Thermal Shutdown .....	56
3.3	Power Saving .....	57
3.3.1	Power Saving while Attached to GSM Networks .....	57
3.4	Power Supply .....	58
3.4.1	Power Supply Ratings .....	59
3.4.2	Minimizing Power Losses .....	61
3.4.3	Measuring the Supply Voltage (VBATT+) .....	61
3.5	Operating Temperatures .....	62
3.5.1	Temperature Allocation Model .....	62
3.6	Electrostatic Discharge .....	63
3.6.1	ESD Protection for Antenna Interface .....	63
3.6.2	Blocking against RF on Interface Lines .....	64
3.7	Reliability Characteristics .....	66
<b>4</b>	<b>Mechanical Dimensions, Mounting and Packaging .....</b>	<b>67</b>
4.1	Mechanical Dimensions of BGS5 .....	67
4.2	Mounting BGS5 onto the Application Platform .....	69
4.2.1	SMT PCB Assembly .....	69
4.2.1.1	Land Pattern and Stencil .....	69
4.2.1.2	Board Level Characterization .....	71
4.2.2	Moisture Sensitivity Level .....	71
4.2.3	Soldering Conditions and Temperature .....	72
4.2.3.1	Reflow Profile .....	72
4.2.3.2	Maximum Temperature and Duration .....	73
4.2.4	Durability and Mechanical Handling .....	74
4.2.4.1	Storage Conditions .....	74
4.2.4.2	Processing Life .....	75
4.2.4.3	Baking .....	75
4.2.4.4	Electrostatic Discharge .....	75
4.3	Packaging .....	76
4.3.1	Tape and Reel .....	76
4.3.1.1	Orientation .....	76
4.3.1.2	Barcode Label .....	77
4.3.2	Shipping Materials .....	78
4.3.2.1	Moisture Barrier Bag .....	78
4.3.2.2	Transportation Box .....	80
4.3.3	Trays .....	81

<b>5</b>	<b>Regulatory and Type Approval Information .....</b>	<b>83</b>
5.1	Directives and Standards .....	83
5.2	SAR requirements specific to portable mobiles .....	86
5.3	Reference Equipment for Type Approval .....	87
5.4	Compliance with FCC and IC Rules and Regulations .....	88
<b>6</b>	<b>Document Information .....</b>	<b>89</b>
6.1	Revision History .....	89
6.2	Related Documents .....	90
6.3	Terms and Abbreviations .....	90
6.4	Safety Precaution Notes .....	94
<b>7</b>	<b>Appendix .....</b>	<b>95</b>
7.1	List of Parts and Accessories .....	95

## Tables

Table 1:	Pad assignments.....	15
Table 2:	Signal properties .....	16
Table 3:	Absolute maximum ratings.....	21
Table 4:	GSM power amplifier absolute maximum ratings.....	21
Table 5:	Signals of the SIM interface (SMT application interface) .....	27
Table 6:	Overview of DAI/PCM lines.....	30
Table 7:	GPIO lines and possible alternative assignment.....	33
Table 8:	Host wakeup lines .....	39
Table 9:	Return loss in the active band.....	41
Table 10:	RF Antenna interface GSM.....	41
Table 11:	Overview of operating modes .....	49
Table 12:	Signal states.....	53
Table 13:	Temperature dependent behavior .....	56
Table 14:	Power supply ratings.....	59
Table 15:	Board temperature .....	62
Table 16:	Temperature allocation model.....	62
Table 17:	Electrostatic values .....	63
Table 18:	EMI measures on the application interface .....	65
Table 19:	Summary of reliability test conditions.....	66
Table 20:	Reflow temperature ratings .....	72
Table 21:	Storage conditions .....	74
Table 22:	Directives .....	83
Table 23:	Standards of North American type approval .....	83
Table 24:	Standards of European type approval.....	84
Table 25:	Requirements of quality .....	84
Table 26:	Standards of the Ministry of Information Industry of the People's Republic of China .....	85
Table 27:	Toxic or hazardous substances or elements with defined concentration limits .....	85
Table 28:	List of parts and accessories.....	95
Table 29:	Molex sales contacts (subject to change) .....	96

## Figures

Figure 1:	BGS5 system overview .....	12
Figure 2:	BGS5 baseband block diagram .....	13
Figure 3:	Numbering plan for connecting pads (bottom view) .....	14
Figure 4:	USB circuit .....	22
Figure 5:	Serial interface ASC0 .....	23
Figure 6:	ASC0 startup behavior .....	24
Figure 7:	Serial interface ASC1 .....	25
Figure 8:	ASC1 startup behavior .....	26
Figure 9:	External UICC/SIM/USIM card holder circuit .....	28
Figure 10:	SIM interface - enhanced ESD protection .....	29
Figure 11:	Long frame PCM timing, 256kHz .....	30
Figure 12:	DAI startup timing .....	31
Figure 13:	RTC supply variants .....	32
Figure 14:	GPIO startup behavior .....	34
Figure 15:	I <sup>2</sup> C interface connected to V180 .....	35
Figure 16:	I <sup>2</sup> C startup behavior .....	36
Figure 17:	Characteristics of SPI modes .....	37
Figure 18:	Status signalling with LED driver .....	38
Figure 19:	Power indication circuit .....	39
Figure 20:	Fast shutdown timing .....	40
Figure 21:	Antenna pads (bottom view) .....	43
Figure 22:	Embedded Stripline on a 0.8mm standard FR4 PCB .....	44
Figure 23:	Micro-Stripline on a 0.8mm standard FR4 PCB .....	44
Figure 24:	Differential 150Ohm lines on a 0.8mm standard FR4 PCB .....	45
Figure 25:	Routing to application's RF connector - top view .....	45
Figure 26:	Schematic diagram of BGS5 sample application .....	47
Figure 27:	Sample level conversion circuit .....	48
Figure 28:	ON circuit sample .....	50
Figure 29:	ON timing .....	51
Figure 30:	Emergency restart timing .....	52
Figure 31:	Switch off behavior .....	54
Figure 32:	Restart circuit using BATT+ line .....	55
Figure 33:	Power saving and paging in GSM networks .....	57
Figure 34:	Power supply limits during transmit burst .....	61
Figure 35:	Position of reference points BATT+ and GND .....	61
Figure 36:	ESD protection for RF antenna interface .....	63
Figure 37:	EMI circuits .....	64
Figure 38:	BGS5- top and bottom view .....	67
Figure 39:	Dimensions of BGS5 (all dimensions in mm) .....	68
Figure 40:	Land pattern (top view) .....	69
Figure 41:	Recommended design for 120 micron thick stencil (top view) .....	70
Figure 42:	Recommended design for 150 micron thick stencil (top view) .....	70
Figure 43:	Reflow Profile .....	72
Figure 44:	Carrier tape .....	76
Figure 45:	Reel direction .....	76
Figure 46:	Barcode label on tape reel .....	77
Figure 47:	Moisture barrier bag (MBB) with imprint .....	78
Figure 48:	Moisture Sensitivity Label .....	79
Figure 49:	Humidity Indicator Card - HIC .....	80
Figure 50:	Small quantity tray .....	81

Figures

---

Figure 51:	Tray to ship odd module amounts.....	81
Figure 52:	Trays with packaging materials.....	81
Figure 53:	Tray dimensions.....	82
Figure 54:	Reference equipment for Type Approval .....	87



# 1 Introduction

This document<sup>1</sup> describes the hardware of the Cinterion® BGS5 module. It helps you quickly retrieve interface specifications, electrical and mechanical details and information on the requirements to be considered for integrating further components.

## 1.1 Key Features at a Glance

Feature	Implementation																														
<i>General</i>																															
Frequency bands	Quad band GSM 850/900/1800/1900MHz <table border="1"> <thead> <tr> <th>Item</th> <th>GSM850</th> <th>GSM900</th> <th>DCS1800</th> <th>PCS1900</th> </tr> </thead> <tbody> <tr> <td>Frequency allocation</td> <td>Tx Uplink: 824-849MHz Rx Downlink: 869-894MHz</td> <td>Tx Uplink: 880-915MHz Rx Downlink: 925-960MHz</td> <td>Tx Uplink: 1710-1785MHz Rx Downlink: 1805-1880MHz</td> <td>Tx Uplink: 1850-1910MHz Rx Downlink: 1930-1990MHz</td> </tr> <tr> <td>Channel band space</td> <td>200KHz</td> <td>200KHz</td> <td>200KHz</td> <td>200KHz</td> </tr> <tr> <td>Channel</td> <td>128-251</td> <td>975-1023 0-124</td> <td>512-885</td> <td>512-810</td> </tr> <tr> <td>Modulation</td> <td>GMSK</td> <td>GMSK</td> <td>GMSK</td> <td>GMSK</td> </tr> <tr> <td>Tx/Rx channel space</td> <td>45MHz</td> <td>45MHz</td> <td>95MHz</td> <td>80MHz</td> </tr> </tbody> </table>	Item	GSM850	GSM900	DCS1800	PCS1900	Frequency allocation	Tx Uplink: 824-849MHz Rx Downlink: 869-894MHz	Tx Uplink: 880-915MHz Rx Downlink: 925-960MHz	Tx Uplink: 1710-1785MHz Rx Downlink: 1805-1880MHz	Tx Uplink: 1850-1910MHz Rx Downlink: 1930-1990MHz	Channel band space	200KHz	200KHz	200KHz	200KHz	Channel	128-251	975-1023 0-124	512-885	512-810	Modulation	GMSK	GMSK	GMSK	GMSK	Tx/Rx channel space	45MHz	45MHz	95MHz	80MHz
Item	GSM850	GSM900	DCS1800	PCS1900																											
Frequency allocation	Tx Uplink: 824-849MHz Rx Downlink: 869-894MHz	Tx Uplink: 880-915MHz Rx Downlink: 925-960MHz	Tx Uplink: 1710-1785MHz Rx Downlink: 1805-1880MHz	Tx Uplink: 1850-1910MHz Rx Downlink: 1930-1990MHz																											
Channel band space	200KHz	200KHz	200KHz	200KHz																											
Channel	128-251	975-1023 0-124	512-885	512-810																											
Modulation	GMSK	GMSK	GMSK	GMSK																											
Tx/Rx channel space	45MHz	45MHz	95MHz	80MHz																											
GSM class	Small MS																														
Output power (according to Release 99, V5)	Class 4 (+33dBm ±2dB) for EGSM850 Class 4 (+33dBm ±2dB) for EGSM900 Class 1 (+30dBm ±2dB) for GSM1800 Class 1 (+30dBm ±2dB) for GSM1900																														
Power supply	3.3V to 4.5V																														
Operating temperature (board temperature)	Normal operation: -30°C to +85°C Extended operation: -40°C to +90°C																														
Physical	Dimensions: 27.6mm x 18.8mm x 2.6mm Weight: approx. 3g																														
RoHS	All hardware components fully compliant with EU RoHS Directive																														

1. The document is effective only if listed in the appropriate Release Notes as part of the technical documentation delivered with your Gemalto M2M product.

## 1.1 Key Features at a Glance

Feature	Implementation
<i>GSM/GPRS features</i>	
Data transfer	GPRS: <ul style="list-style-type: none"> <li>• Multislot Class 12</li> <li>• Full PBCCH support</li> <li>• Mobile Station Class B</li> <li>• Coding Scheme 1 – 4</li> </ul> CSD: <ul style="list-style-type: none"> <li>• V.110, RLP, non-transparent</li> <li>• 9.6kbps</li> <li>• USSD</li> </ul>
SMS	Point-to-point MT and MO Cell broadcast Text and PDU mode Storage: SIM card plus SMS locations in mobile equipment
<i>Software</i>	
AT commands	Hayes 3GPP TS 27.007, TS 27.005, Gemalto M2M AT commands
SIM Application Toolkit	SAT Release 99
Firmware update	Generic update from host application over ASC0 or USB modem.
<i>Interfaces</i>	
Module interface	Surface mount device with solderable connection pads (SMT application interface). Land grid array (LGA) technology ensures high solder joint reliability and provides the possibility to use an optional module mounting socket. For more information on how to integrate SMT modules see also <a href="#">[3]</a> . This application note comprises chapters on module mounting and application layout issues as well as on SMT application development equipment.
USB	USB 2.0 Full Speed (12Mbit/s) device interface
2 serial interfaces	ASC0 (shared with GPIO lines): <ul style="list-style-type: none"> <li>• 8-wire modem interface with status and control lines, unbalanced, asynchronous</li> <li>• Adjustable baud rates: 1,200bps to 921,600bps</li> <li>• Autobauding: 1,200bps to 230,400bps</li> <li>• Supports RTS0/CTS0 hardware flow control.</li> <li>• Multiplex ability according to GSM 07.10 Multiplexer Protocol.</li> </ul> ASC1 (shared with GPIO lines): <ul style="list-style-type: none"> <li>• 4-wire, unbalanced asynchronous interface</li> <li>• Adjustable baud rates: 1,200bps to 921,600bps</li> <li>• Autobauding: 1,200bps to 230,400bps</li> <li>• Supports RTS1/CTS1 hardware flow control</li> </ul>
Audio	1 digital interface (PCM), shared with GPIO lines
UICC interface	Supported SIM/USIM cards: 3V, 1.8V
GPIO interface	9 GPIO lines shared with ASC0 lines, LED signalling, PWM functionality, fast shutdown and pulse counter 4 GPIO lines shared with PCM interface 4 GPIO lines shared with ASC1 and SPI interfaces

## 1.1 Key Features at a Glance

Feature	Implementation
I <sup>2</sup> C interface	Supports I <sup>2</sup> C serial interface
SPI interface	Serial peripheral interface, shared with GPIO and ASC1 lines
Antenna interface pads	50Ω
<i>Power on/off, Reset</i>	
Power on/off	Switch-on by hardware signal ON Switch-off by AT command Switch off by hardware signal GPIO4/FST_SHDN instead of AT command Automatic switch-off in case of critical temperature and voltage conditions
Reset	Orderly shutdown and reset by AT command Emergency reset by hardware signal EMERG_RST
<i>Special features</i>	
Real time clock	Timer functions via AT commands
Phonebook	SIM and phone
TTY/CTM support	Integrated CTM modem
<i>Evaluation kit</i>	
Evaluation module	BGS5 module soldered onto a dedicated PCB that can be connected to an adapter in order to be mounted onto the DSB75.
DSB75	DSB75 Development Support Board designed to test and type approve Gemalto M2M modules and provide a sample configuration for application engineering. A special adapter is required to connect the BGS5 evaluation module to the DSB75.

## 1.2 BGS5 System Overview

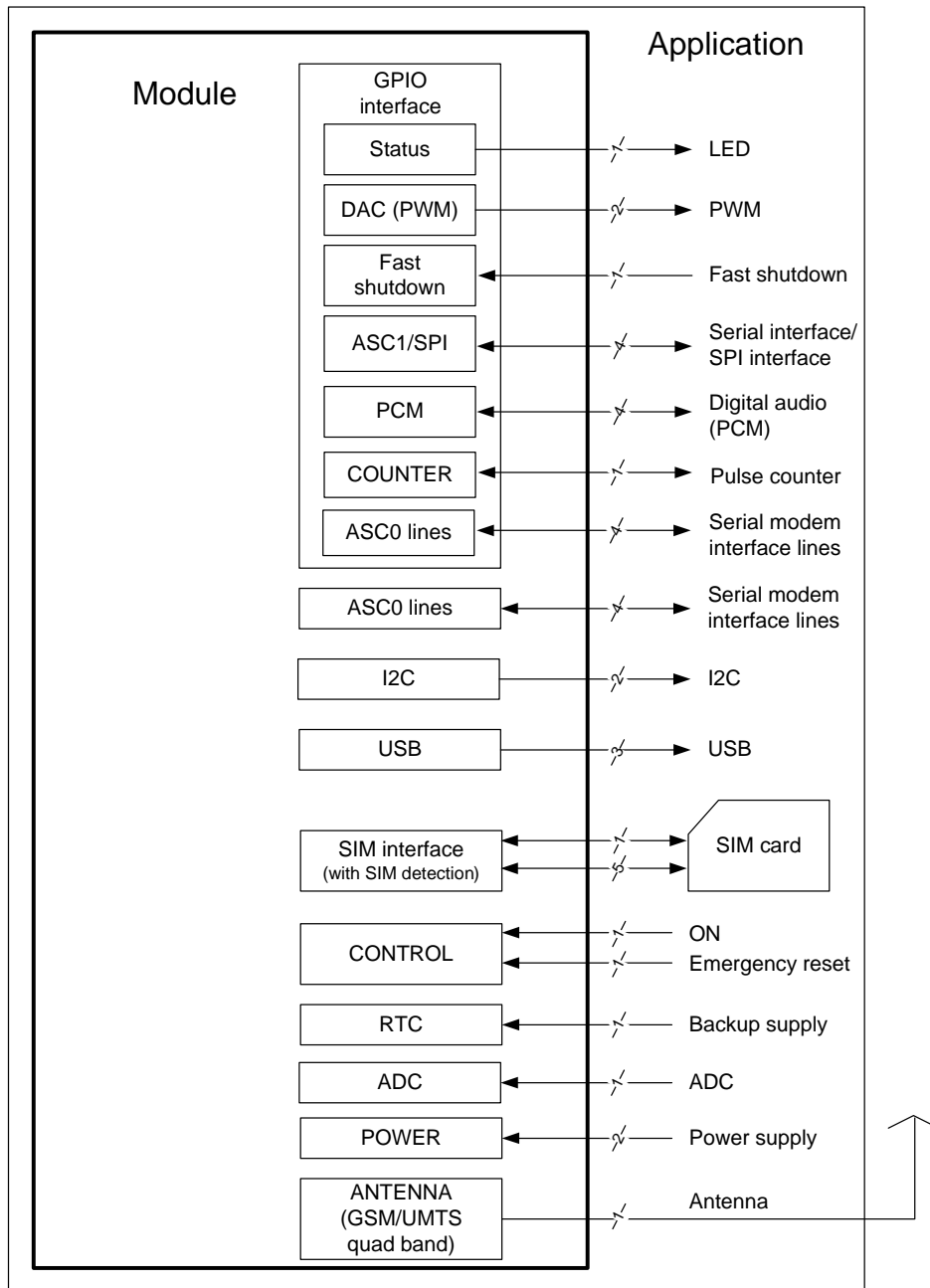

Figure 1: BGS5 system overview

1.3 Circuit Concept

### 1.3 Circuit Concept

Figure 2 shows a block diagram of the BGS5 module and illustrates the major functional components:

Baseband block:

- GSM baseband processor and power management
- Stacked flash/PSRAM memory
- Application interface (SMT with connecting pads)

GSM RF section:

- RF transceiver (part of baseband processor IC)
- RF power amplifier/front-end module inc. harmonics filtering
- Receive SAW filters

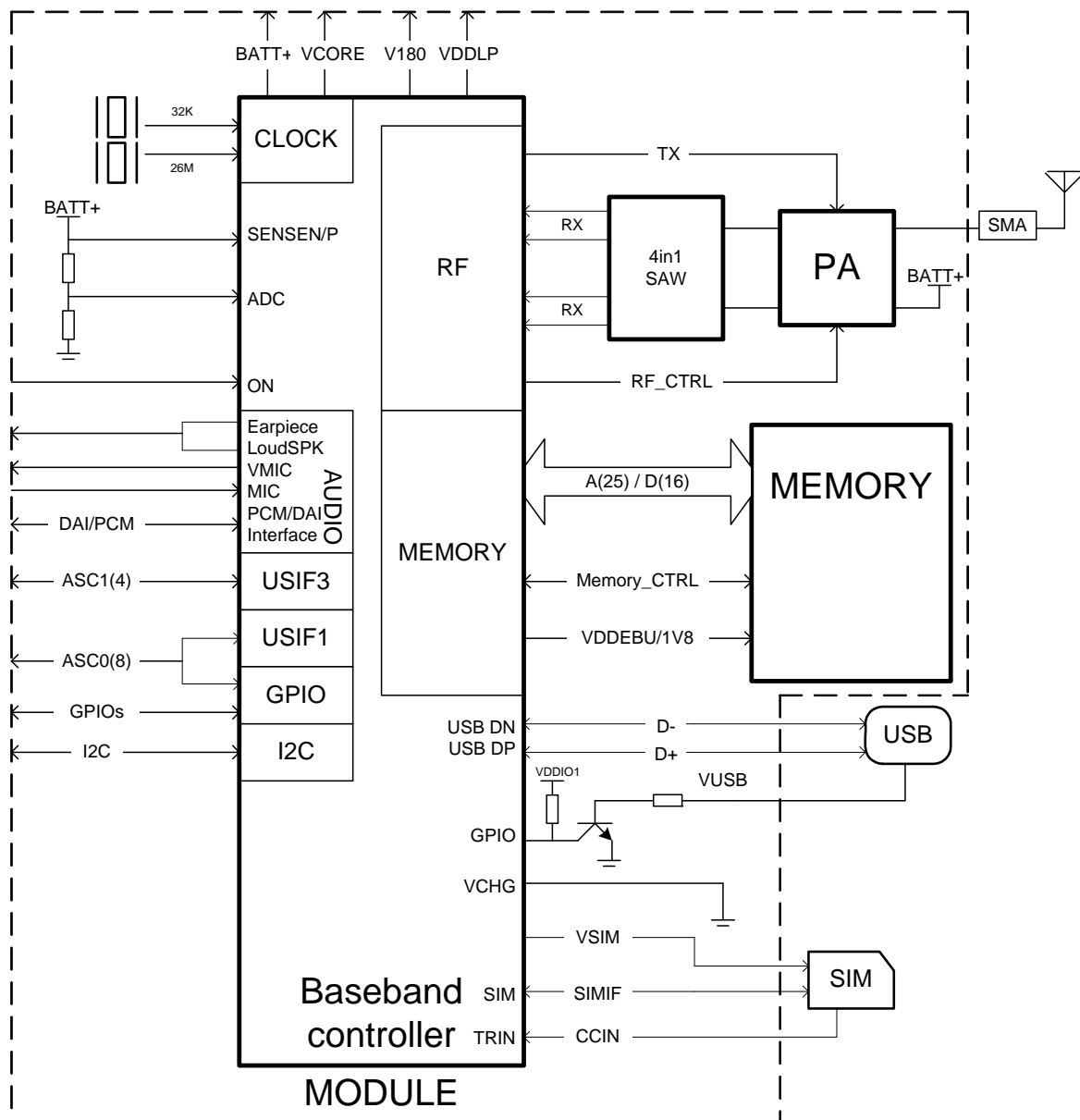

Figure 2: BGS5 baseband block diagram

## 2 Interface Characteristics

BGS5 is equipped with an SMT application interface that connects to the external application. The SMT application interface incorporates the various application interfaces as well as the RF antenna interface.

### 2.1 Application Interface

#### 2.1.1 Pad Assignment

The SMT application interface on the BGS5 provides connecting pads to integrate the module into external applications. Figure 3 shows the connecting pads' numbering plan, the following Table 1 lists the pads' assignments.

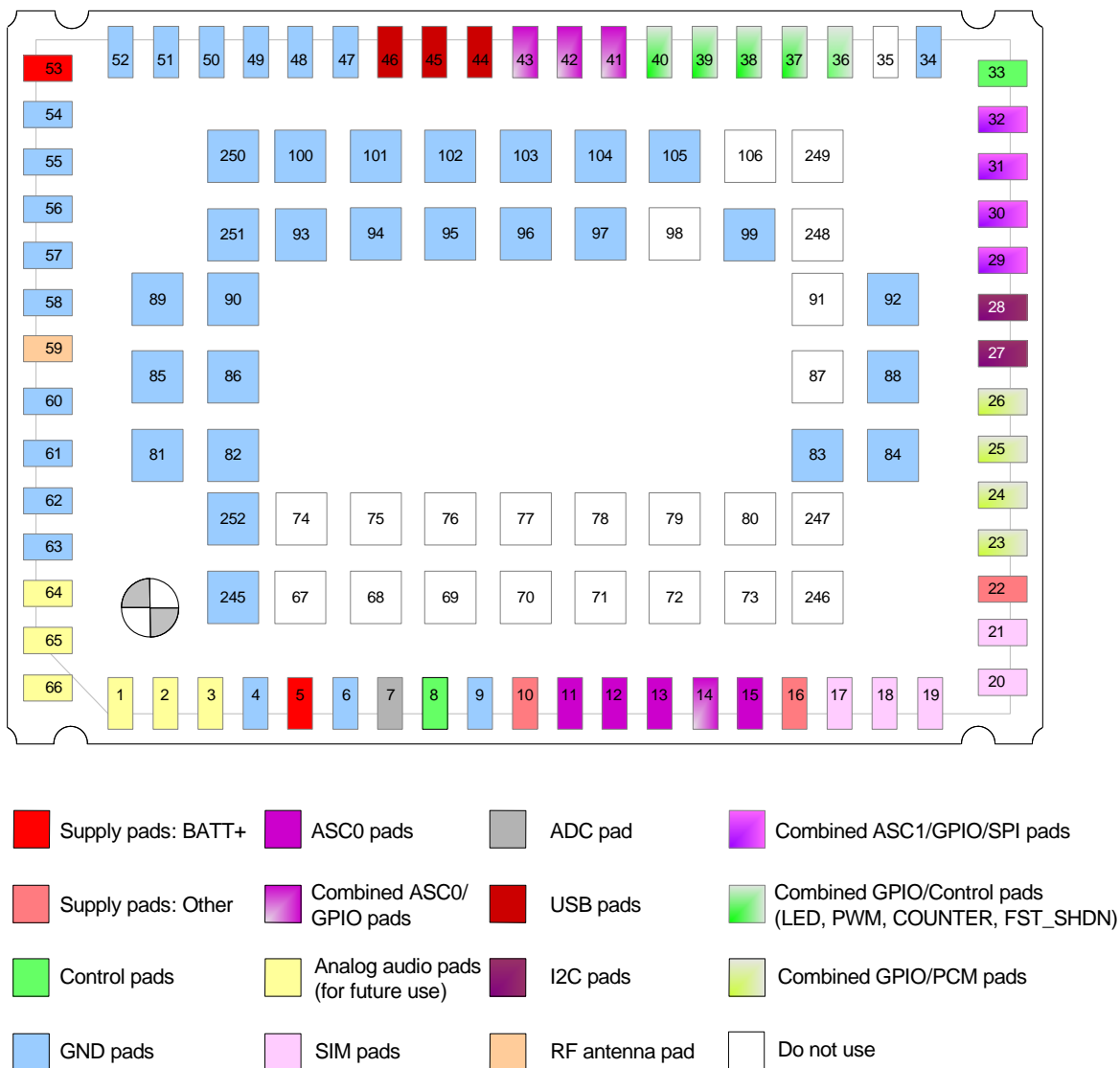

Figure 3: Numbering plan for connecting pads (bottom view)

## 2.1 Application Interface

Table 1: Pad assignments

Pad no.	Signal name	Pad no.	Signal name	Pad no.	Signal name
1	VMIC <sup>1</sup>	23	GPIO20/TXDDAI	45	USB_DP
2	EPN <sup>1</sup>	24	GPIO22/TFSDAI	46	USB_DN
3	EPP <sup>1</sup>	25	GPIO21/RXDDAI	47	GND
4	GND	26	GPIO23/SCLK	48	GND
5	BATT+	27	I2CDAT	49	GND
6	GND	28	I2CCLK	50	GND
7	ADC1	29	TXD1/GPIO17/MISO	51	GND
8	ON	30	RXD1/GPIO16/MOSI	52	GND
9	GND	31	RTS1/GPIO18/SPI_CLK	53	BATT+
10	V180	32	CTS1/GPIO19/SPI_CS	54	GND
11	RXD0	33	EMERG_RST	55	GND
12	CTS0	34	GND	56	GND
13	TXD0	35	Do not use	57	GND
14	RING0/GPIO24	36	GPIO8/COUNTER	58	GND
15	RTS0	37	GPIO7/PWM1	59	RF_OUT
16	VDDL	38	GPIO6/PWM2	60	GND
17	CCRST	39	GPIO5/LED	61	GND
18	CCIN	40	GPIO4/FST_SHDN	62	GND
19	CCIO	41	DSR0/GPIO3	63	GND
20	CCVCC	42	DCD0/GPIO2	64	AGND <sup>1</sup>
21	CCCLK	43	DTR0/GPIO1	65	MICP <sup>1</sup>
22	VCORE	44	VUSB	66	MICN <sup>1</sup>
Centrally located pads					
67	Do not use	83	GND	99	GND
68	Do not use	84	GND	100	GND
69	Do not use	85	GND	101	GND
70	Do not use	86	GND	102	GND
71	Do not use	87	Do not use	103	GND
72	Do not use	88	GND	104	GND
73	Do not use	89	GND	105	GND
74	Do not use	90	GND	106	Do not use
75	Do not use	91	Do not use	245	Do not use
76	Do not use	92	GND	246	Do not use
77	Do not use	93	GND	247	Do not use
78	Do not use	94	GND	248	Do not use
79	Do not use	95	GND	249	Do not use
80	Do not use	96	GND	250	GND
81	GND	97	GND	251	GND
82	GND	98	Do not use	252	GND

1. Do not use. Hardware prepared for future use as analog audio interface.

Signal pads that are not used should not be connected to an external application.

Please note that the reference voltages listed in [Table 2](#) are the values measured directly on the BGS5 module. They do not apply to the accessories connected.

## 2.1.2 Signal Properties

**Table 2:** Signal properties

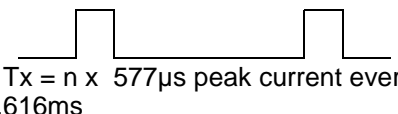
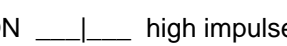
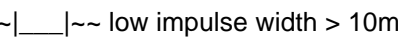
Function	Signal name	IO	Signal form and level	Comment								
Power supply	BATT+ GSM activated	I	$V_{I\max} = 4.5V$ $V_{I\text{norm}} = 4.0V$ $V_{I\min} = 3.3V$ during Tx burst on board  $I \approx 1.64A$ , during Tx burst (GSM)   $n \text{ Tx} = n \times 577\mu\text{s}$ peak current every 4.616ms	<p>Lines of BATT+ and GND must be connected in parallel for supply purposes because higher peak currents may occur.</p> <p>Minimum voltage must not fall below 3.3V including drop, ripple, spikes.</p> <p>BATT+ assigned to pad 5 requires an additional ESR 150<math>\mu</math>F capacitor.</p>								
Power supply	GND		Ground	Application Ground								
External supply voltage	V180	O	Normal operation: $V_{O\text{norm}} = 1.80V \pm 3\%$ $I_{O\max} = -10mA$ SLEEP mode Operation: $V_{O\text{Sleep}} = 1.80V \pm 5\%$ $I_{O\max} = -10mA$  $CL_{\max} = 100nF$	<p>V180 may be used to supply level shifters at the interfaces or to supply external application circuits.</p> <p>VCORE and V180 should be used for the power indication circuit.</p>								
	VCORE	O	Normal operation: $V_{O\text{norm}} = 1.25V \pm 3\%$ $I_{O\max} = -10mA$ SLEEP mode Operation: $V_{O\text{Sleep}} = 1.0V \pm 3\%$ $I_{O\max} = -10mA$  $CL_{\max} = 100nF$	<p>If unused keep line open.</p>								
Ignition	ON	I	$V_{IH\max} = VDDLP + 0.3V$ $V_{IH\min} = 1.2V$ $V_{IL\max} = 0.5V$  <table border="1" data-bbox="638 1512 1053 1624"> <thead> <tr> <th>Rise time</th> <th>Min</th> <th>Typ</th> <th>Max</th> </tr> </thead> <tbody> <tr> <td></td> <td>50<math>\mu</math>s</td> <td>60<math>\mu</math>s</td> <td>80<math>\mu</math>s</td> </tr> </tbody> </table> Min low time before rising edge $\geq 100\mu\text{s}$  ON  high impulse	Rise time	Min	Typ	Max		50 $\mu$ s	60 $\mu$ s	80 $\mu$ s	<p>This signal switches the module ON. For more information and requirements see also <a href="#">Section 3.2.1.1</a>.</p> <p>Set this signal low before and after the startup impulse.</p>
Rise time	Min	Typ	Max									
	50 $\mu$ s	60 $\mu$ s	80 $\mu$ s									
Emergency restart	EMERG_RST	I	$R_1 \approx 1k\Omega$ , $C_1 \approx 1nF$ $V_{OH\max} = 1.85V$ $V_{IH\min} = 1.30V$ $V_{IL\max} = 0.35V$   low impulse width > 10ms	<p>This line must always be connected to V180 with a 2.2KOhm pull-up resistor. To drive this line low an open drain or open collector driver connected to GND should be used.</p>								



## 2.1 Application Interface

Table 2: Signal properties

Function	Signal name	IO	Signal form and level	Comment
Fast shutdown	GPIO4	I	$V_{ILmax} = 0.35V$ $V_{IHmin} = 1.30V$ $V_{IHmax} = 1.85V$  ~- ___ ~- low impulse width > 10ms	This line must be driven low. If unused keep line open.  Note that if configured as fast shutdown line the listed GPIO line is identical to the following signal: GPIO4 --> FST_SHDN
RTC backup	VDDL	I/O	$V_{Onorm} = 2.3V$ $I_{Omax} = 12mA$  $V_{Imin} = 1.0V$ $V_{Imax} = 2.75V$	It is recommended to use a serial resistor between VDDL and a possible capacitor or chargeable battery.  If unused keep line open.
USB	VUSB_IN	I	$V_{Imin} = 3V$ $V_{Imax} = 5.25V$	All electrical characteristics according to USB Implementers' Forum, USB 2.0 Specification.  If unused keep lines open.
	USB_DN	I/O	Full speed signal characteristics according USB 2.0 Specification.	
	USB_DP			
Serial Interface ASC0	RXD0	O	$V_{OLmax} = 0.2V$ at $I = +0.1mA$ $V_{OHmin} = 1.55V$ at $I = -0.1mA$ $V_{OHmax} = 1.85V$	If unused keep lines open.  Note that some ASC0 lines are shared with the following GPIO lines: DTR0 --> GPIO1 DCD0 --> GPIO2 DSR0 --> GPIO3 RING0 --> GPIO24
	CTS0	O		
	DCD0	O		
	RING0	O		
	DSR0	O		
	TXD0	I	$V_{ILmax} = 0.35V$ $V_{IHmin} = 1.30V$ $V_{IHmax} = 1.85V$	
	RTS0	I	Pull down resistor active $V_{ILmax} = 0.35V$ at $> 11\mu A$ $V_{IHmin} = 1.30V$ at $< 43\mu A$ $V_{IHmax} = 1.85V$ at $< 43\mu A$	
DTR0	I	Pull up resistor active $V_{ILmax} = 0.35V$ at $< -105\mu A$ $V_{IHmin} = 1.30V$ at $> -35\mu A$ $V_{IHmax} = 1.85V$		
Serial Interface ASC1	RXD1	O	$V_{OLmax} = 0.25V$ at $I = 1mA$ $V_{OHmin} = 1.55V$ at $I = -1mA$ $V_{OHmax} = 1.85V$	If unused keep line open.  Note that the ASC1 interface lines are shared with GPIO lines as follows: RXD1 --> GPIO16 TXD1 --> GPIO17 RTS1 --> GPIO18 CTS1 --> GPIO19
	TXD1	I		
	RTS1	I	$V_{ILmax} = 0.35V$ $V_{IHmin} = 1.30V$ $V_{IHmax} = 1.85V$	
	CTS1	O		

## 2.1 Application Interface

Table 2: Signal properties

Function	Signal name	IO	Signal form and level	Comment
I <sup>2</sup> C	I2CCLK	IO	Open drain IO $V_{OLmin} = 0.35V$ at $I = -3mA$ $V_{OHmax} = 1.85V$ $R$ external pull up min = 560Ohm  $V_{ILmax} = 0.35V$ $V_{IHmin} = 1.3V$ $V_{IHmax} = 1.85V$	According to the I <sup>2</sup> C Bus Specification Version 2.1 for the fast mode a rise time of max. 300ns is permitted. There is also a maximum $V_{OL}=0.4V$ at 3mA specified.  The value of the pull-up depends on the capacitive load of the whole system (I <sup>2</sup> C Slave + lines). The maximum sink current of I2CDAT and I2CCLK is 4mA.  If lines are unused keep lines open.
	I2CDAT	IO		
SPI	GPIO16	O	$V_{OLmax} = 0.2V$ at $I = +0.1mA$ $V_{OHmin} = 1.6V$ at $I = -0.1mA$ $V_{OHmax} = 1.85V$  $V_{ILmax} = 0.35V$ $V_{IHmin} = 1.30V$ $V_{IHmax} = 1.85V$	If lines are unused keep lines open.  Note that if configured as SPI interface the listed GPIO lines are identical to following SPI signals: GPIO16 --> MOSI GPIO17 --> MISO GPIO18 --> SPI_CLK GPIO19 --> SPI_CS
	GPIO17	I		
	GPIO18	O		
	GPIO19	O		
GPIO interface	GPIO1-GPIO3	IO	$V_{OLmax} = 0.2V$ at $I = +0.1mA$ $V_{OHmin} = 1.6V$ at $I = -0.1mA$ $V_{OHmax} = 1.85V$  $V_{ILmax} = 0.35V$ $V_{IHmin} = 1.30V$ $V_{IHmax} = 1.85V$	If unused keep line open.  Please note that some GPIO lines are or can be configured for functions other than GPIO: GPIO1-GPIO3: ASC0 control lines DTR0, DCD0 and DSR0 GPIO4: Fast shutdown GPIO5: Status LED line GPIO6/GPIO7: PWM GPIO8: Pulse counter GPIO16-GPIO19: ASC1 or SPI GPIO20-GPIO23: PCM GPIO24: ASC0 control line RING0
	GPIO4	IO		
	GPIO5	IO		
	GPIO6	IO		
	GPIO7	IO		
	GPIO8	IO		
	GPIO16-GPIO19	IO		
	GPIO20-GPIO23	IO		
GPIO24	IO			

## 2.1 Application Interface

Table 2: Signal properties

Function	Signal name	IO	Signal form and level	Comment	
Digital audio interface (PCM)	GPIO22	O	$V_{OLmax} = 0.2V$ at $I = +0.1mA$ $V_{OHmin} = 1.6V$ at $I = -0.1mA$ $V_{OHmax} = 1.85V$	If unused keep line open.  Note that if configured as PCM interface the listed GPIO lines are identical to following PCM signals: GPIO22 --> TFSDAI GPIO23 --> SCLK GPIO20 --> TXDDAI GPIO21 --> RXDDAI	
	GPIO23	O			
	GPIO20	O			
	GPIO21	I	$V_{ILmax} = 0.35V$ $V_{IHmin} = 1.30V$ $V_{IHmax} = 1.85V$		
Status LED	GPIO5	O	$V_{OLmax} = 0.2V$ at $I = +0.1mA$ $V_{OHmin} = 1.6V$ at $I = -0.1mA$ $V_{OHmax} = 1.85V$	If unused keep line open.	
PWM	GPIO6	O	$V_{OLmax} = 0.2V$ at $I = +0.1mA$ $V_{OHmin} = 1.6V$ at $I = -0.1mA$ $V_{OHmax} = 1.85V$	If unused keep lines open.	
	GPIO7	O			
Pulse counter	GPIO8	I	Internal up resistor active $V_{ILmax} = 0.35V$ at $< -105\mu A$ $V_{IHmin} = 1.30V$ at $> -35\mu A$ $V_{IHmax} = 1.85V$	If unused keep line open.	
ADC (Analog-to-Digital converter)	ADC1	I	$R_I = 1M\Omega$ $V_I = 0V \dots 1.14V$ (valid range) $V_{IHmax} = 1.14V$  Resolution 1024 steps Tolerance 0.3%	ADC1 can be used as input for external measurements.  If unused keep line open.	
SIM card detection	CCIN	I	$R_I \approx 110k\Omega$ $V_{IHmin} = 1.3$ $V_{IHmax} = 1.85V$ $V_{ILmax} = 0.35V$	CCIN = High, SIM card inserted.  For details please refer to <a href="#">Section 2.1.6</a> .  If unused keep line open.	
3V SIM Card Interface	CCRST	O	$V_{OLmax} = 0.25V$ at $I = 1mA$ $V_{OHmin} = 2.45V$ at $I = -1mA$ $V_{OHmax} = 2.90V$	Maximum cable length or copper track to SIM card holder should not exceed 100mm.	
	CCIO	I/O			$V_{ILmax} = 0.50V$ $V_{IHmin} = 2.05V$ $V_{IHmax} = 2.90V$  $V_{OLmax} = 0.25V$ at $I = 1mA$ $V_{OHmin} = 2.50V$ at $I = -1mA$ $V_{OHmax} = 2.90V$
	CCCLK	O			$V_{OLmax} = 0.25V$ at $I = 1mA$ $V_{OHmin} = 2.40V$ at $I = -1mA$ $V_{OHmax} = 2.90V$
	CCVCC	O			$V_{Omin} = 2.80V$ $V_{Otyp} = 2.85V$ $V_{Omax} = 2.90V$ $I_{Omax} = -30mA$

## 2.1 Application Interface

Table 2: Signal properties

Function	Signal name	IO	Signal form and level	Comment
1.8V SIM Card Interface	CCRST	O	$V_{OLmax} = 0.25V$ at $I = 1mA$ $V_{OHmin} = 1.45V$ at $I = -1mA$ $V_{OHmax} = 1.90V$	
	CCIO	I/O	$V_{ILmax} = 0.35V$ $V_{IHmin} = 1.25V$ $V_{IHmax} = 1.85V$  $V_{OLmax} = 0.25V$ at $I = 1mA$ $V_{OHmin} = 1.50V$ at $I = -1mA$ $V_{OHmax} = 1.85V$	
	CCCLK	O	$V_{OLmax} = 0.25V$ at $I = 1mA$ $V_{OHmin} = 1.50V$ at $I = -1mA$ $V_{OHmax} = 1.85V$	
	CCVCC	O	$V_{Omin} = 1.75V$ $V_{Otyp} = 1.80V$ $V_{Omax} = 1.85V$ $I_{Omax} = -30mA$	

### 2.1.2.1 Absolute Maximum Ratings

The absolute maximum ratings stated in [Table 3](#) are stress ratings under any conditions. Stresses beyond any of these limits will cause permanent damage to BGS5.

**Table 3:** Absolute maximum ratings

Parameter	Min	Max	Unit
Supply voltage BATT+ (no service)	-0.3	+5.5	V
Voltage at all digital lines in POWER DOWN mode	-0.3	+0.3	V
Voltage at digital lines in normal operation	-0.4	V180 + 0.4	V
Current at digital lines in normal operation	-	5mA	mA
Voltage at SIM/USIM interface, CCVCC in normal operation	-0.3	+3.6	V
Current at SIM/USIM interface 1.8V and 2.85V operation	-		mA
Voltage at ADC line in normal operation	0	1.14	V
VDDL input voltage	-0.15	2.5	V
Current at VDDL in normal operation	-	+25	mA
V180 in normal operation	+1.7	+1.9	V
Current at V180 in normal operation			mA
VCORE in normal operation	+1	+1.25	V
Current at VCORE in normal operation		+550	mA

### Absolute maximum ratings for the module's internal GSM power amplifier

**Table 4:** GSM power amplifier absolute maximum ratings

Power amplifier parameter	Specification		
	Min	Typical	Max
Power supply voltage	3.2V	3.8V	4.5V
Power supply current	0mA	210mA	1.3A

### 2.1.3 USB Interface

BGS5 supports a USB 2.0 Full Speed (12Mbit/s) device interface. The USB interface is primarily intended for use as command and data interface and for downloading firmware.

The USB host is responsible for supplying the VUSB\_IN line. This line is for voltage detection only. The USB part (driver and transceiver) is supplied by means of BATT+. This is because BGS5 is designed as a self-powered device compliant with the “Universal Serial Bus Specification Revision 2.0”<sup>1</sup>.

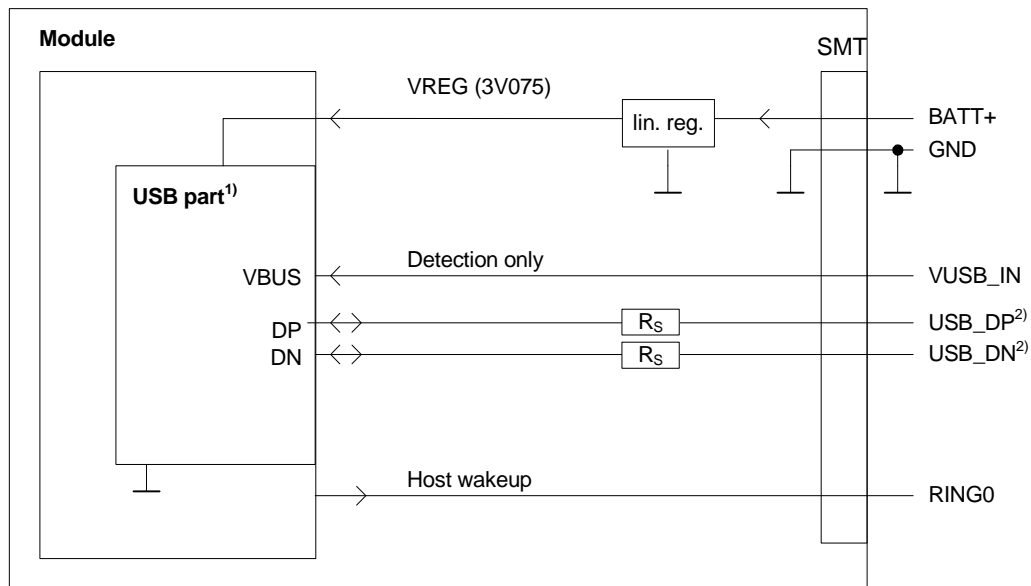

<sup>1</sup> All serial (including R<sub>S</sub>) and pull-up resistors for data lines are implemented.

<sup>2</sup> If the USB interface is operated in High Speed mode (480MHz), it is recommended to take special care routing the data lines USB\_DP and USB\_DN. Application layout should in this case implement a differential impedance of 90Ohm for proper signal integrity.

**Figure 4:** USB circuit

To properly connect the module's USB interface to the host a USB 2.0 compatible connector is required. For more information on the USB related signals see [Table 2](#). Furthermore, the USB modem driver distributed with BGS5 needs to be installed.

While the USB connection is active, the module will not change into SLEEP mode. Switching between active and SLEEP mode is controlled by the VUSB\_IN signal. Only if VUSB\_IN is low, will the module switch to SLEEP mode. Therefore, VUSB\_IN must be disabled or set to low first, before the module can switch to SLEEP mode. If the module is in SLEEP mode, a high VUSB\_IN signal level will wake up the module again, and switch to active mode. On an incoming call BGS5 does generate a remote wake up request to resume the USB connection.

As an alternative to the regular USB remote wakeup mechanism it is possible to employ the RING0 line to wake up the host application. The benefit is that the RING0 line can wake up the host application in case of incoming calls or other events signaled by URCs while the USB interface is suspended or shut down. For details on this host wakeup interface see [Section 2.1.14.3](#).

1. The specification is ready for download on <http://www.usb.org/developers/docs/>

### 2.1.4 Serial Interface ASC0

BGS5 offers an 8-wire unbalanced, asynchronous modem interface ASC0 conforming to ITU-T V.24 protocol DCE signalling. The electrical characteristics do not comply with ITU-T V.28. The significant levels are 0V (for low data bit or active state) and 1.8V (for high data bit or inactive state). For electrical characteristics please refer to [Table 2](#). For an illustration of the interface line's startup behavior see [Figure 6](#).

BGS5 is designed for use as a DCE. Based on the conventions for DCE-DTE connections it communicates with the customer application (DTE) using the following signals:

- Port TXD @ application sends data to the module's TXD0 signal line
- Port RXD @ application receives data from the module's RXD0 signal line

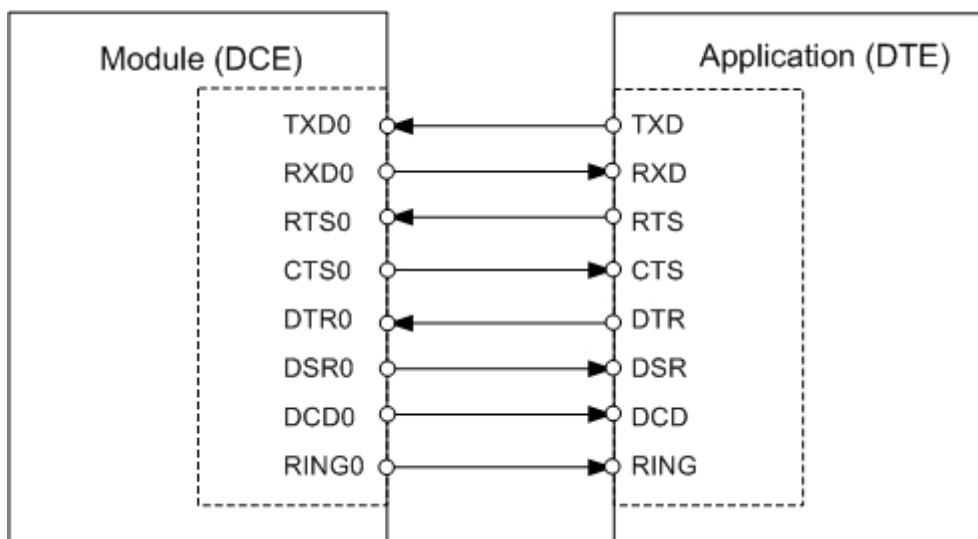

Figure 5: Serial interface ASC0

#### Features:

- Includes the data lines TXD0 and RXD0, the status lines RTS0 and CTS0 and, in addition, the modem control lines DTR0, DSR0, DCD0 and RING0.
- ASC0 is designed for controlling GSM voice calls, transferring data and for controlling the module with AT commands.
- Full multiplexing capability allows the interface to be partitioned into virtual channels.
- The RING0 signal serves to indicate incoming calls and other types of URCs (Unsolicited Result Code). It can also be used to send pulses to the host application, for example to wake up the application from power saving state.
- Configured for 8 data bits, no parity and 1 stop bit.
- ASC0 can be operated at fixed bit rates from 1200bps up to 921600bps.
- Autobauding supports bit rates from 1200bps up to 230400bps.
- Supports RTS0/CTS0 hardware flow control. The hardware hand shake line RTS0 has an internal pull down resistor causing a low level signal, if the line is not used and open. Although hardware flow control is recommended, this allows communication by using only RXD and TXD lines.
- Wake up from SLEEP mode by RTS0 activation (high to low transition).

**Note:** Initially, the ASC0 modem control lines are available as serial interface lines. However, these lines can alternatively be configured as GPIO1 (DTR0), GPIO2 (DCD0), GPIO3 (DSR0)

and GPIO24 (RING0) lines. Configuration is done by AT command (see [1]). The configuration is non-volatile and becomes active after a module restart.

Also note that the DSR0, DCD0 and RING0 modem control lines are driven only with an internal pull-up or pull-down resistor to change the modem signal state.

The following figure shows the startup behavior of the asynchronous serial interface ASC0.

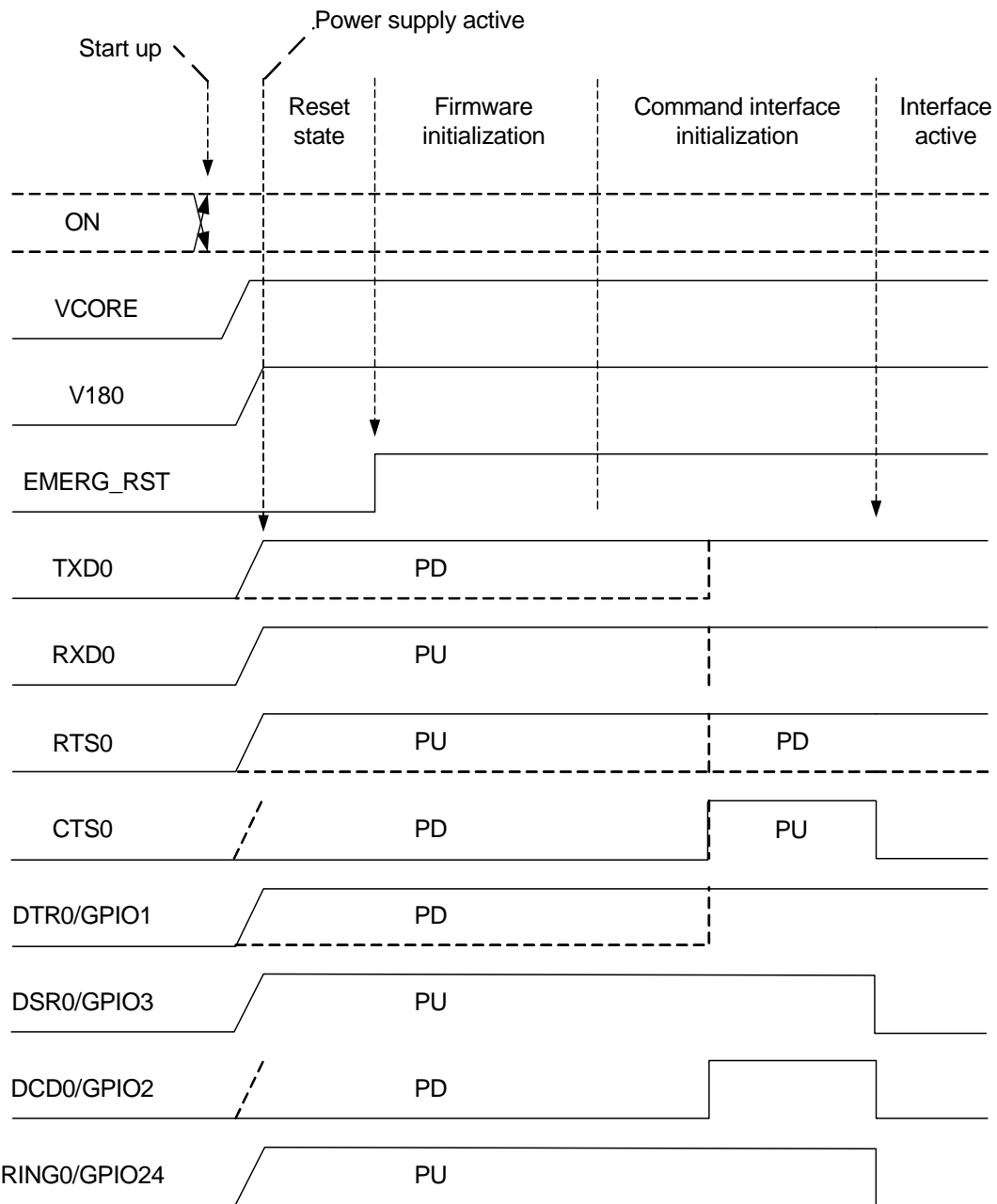

\*) For pull-up and pull-down values see Table 11.

Figure 6: ASC0 startup behavior

Please note that during startup the DTR0 signal is driven active low for 500µs. It is recommended to provide a 470 Ohm serial resistor for the DTR0 line to prevent shorts.

Also note that no data must be sent over the ASC0 interface before the interface is active and ready to receive data (see Section 3.2.1.1).



### 2.1.5 Serial Interface ASC1

Four BGS5 GPIO lines can be configured as ASC1 interface signals to provide a 4-wire unbalanced, asynchronous modem interface ASC1 conforming to ITU-T V.24 protocol DCE signaling. The electrical characteristics do not comply with ITU-T V.28. The significant levels are 0V (for low data bit or active state) and 1.8V (for high data bit or inactive state). For electrical characteristics please refer to [Table 2](#). For an illustration of the interface line's startup behavior see [Figure 8](#).

The following four GPIO lines are by default configured as ASC1 interface signals:  
GPIO16 --> RXD1, GPIO17 --> TXD1, GPIO18 --> RTS1 and GPIO19 --> CTS1.

The default GPIO configuration as ASC1 lines can be changed by AT command (see [\[1\]](#)). A change is non-volatile and becomes active after a module restart.

BGS5 is designed for use as a DCE. Based on the conventions for DCE-DTE connections it communicates with the customer application (DTE) using the following signals:

- Port TXD @ application sends data to module's TXD1 signal line
- Port RXD @ application receives data from the module's RXD1 signal line

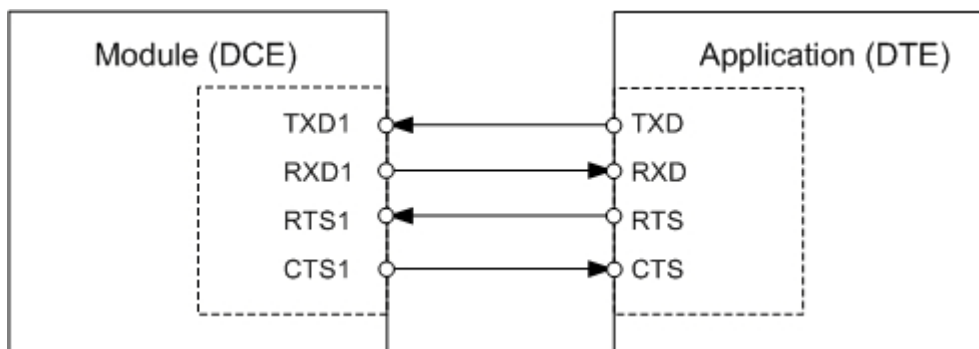

Figure 7: Serial interface ASC1

#### Features

- Includes only the data lines TXD1 and RXD1 plus RTS1 and CTS1 for hardware hand-shake.
- On ASC1 no RING line is available.
- Configured for 8 data bits, no parity and 1 or 2 stop bits.
- ASC1 can be operated at fixed bit rates from 1,200 bps to 921600 bps.
- Autobauding supports bit rates from 1200bps up to 230400bps.
- Supports RTS1/CTS1 hardware flow control. The hardware hand shake line RTS1 has an internal pull down resistor causing a low level signal, if the line is not used and open. Although hardware flow control is recommended, this allows communication by using only RXD and TXD lines.

The following figure shows the startup behavior of the asynchronous serial interface ASC1.

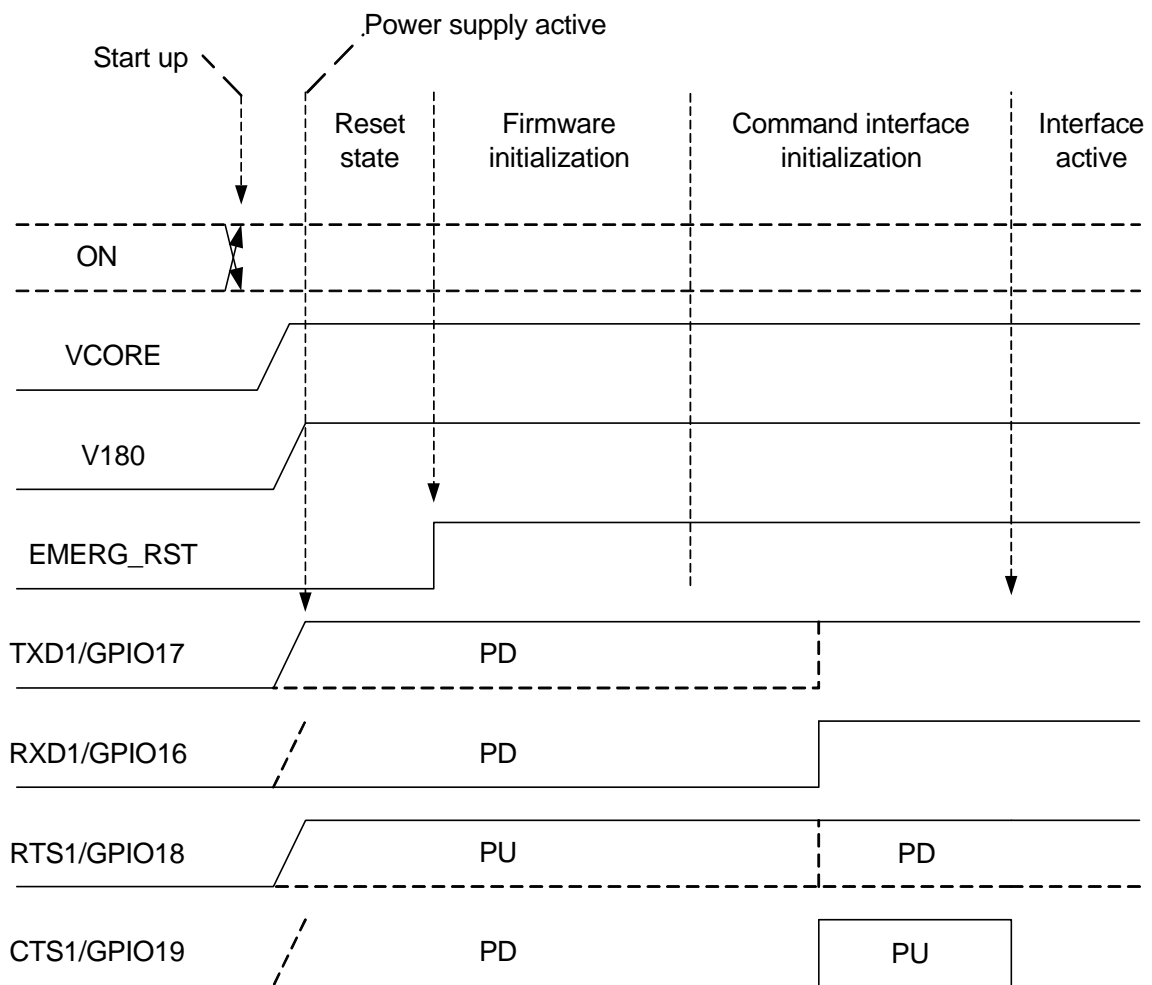

Figure 8: ASC1 startup behavior

## 2.1.6 UICC/SIM/USIM Interface

BGS5 has an integrated UICC/SIM/USIM interface compatible with the 3GPP 31.102 and ETSI 102 221. This is wired to the host interface in order to be connected to an external SIM card holder. Five pads on the SMT application interface are reserved for the SIM interface.

The UICC/SIM/USIM interface supports 3V and 1.8V SIM cards. Please refer to [Table 2](#) for electrical specifications of the UICC/SIM/USIM interface lines depending on whether a 3V or 1.8V SIM card is used.

The CCIN signal serves to detect whether a tray (with SIM card) is present in the card holder. Using the CCIN signal is mandatory for compliance with the GSM 11.11 recommendation if the mechanical design of the host application allows the user to remove the SIM card during operation. To take advantage of this feature, an appropriate SIM card detect switch is required on the card holder. For example, this is true for the model supplied by Molex, which has been tested to operate with BGS5 and is part of the Gemalto M2M reference equipment submitted for type approval. See [Section 7.1](#) for Molex ordering numbers.

**Table 5:** Signals of the SIM interface (SMT application interface)

Signal	Description
GND	Separate ground connection for SIM card to improve EMC.
CCCLK	Chipcard clock
CCVCC	SIM supply voltage.
CCIO	Serial data line, input and output.
CCRST	Chipcard reset
CCIN	Input on the baseband processor for detecting a SIM card tray in the holder. If the SIM is removed during operation the SIM interface is shut down immediately to prevent destruction of the SIM. The CCIN signal is by default low and will change to high level if a SIM card is inserted. The CCIN signal is mandatory for applications that allow the user to remove the SIM card during operation. The CCIN signal is solely intended for use with a SIM card. It must not be used for any other purposes. Failure to comply with this requirement may invalidate the type approval of BGS5.

*Note: No guarantee can be given, nor any liability accepted, if loss of data is encountered after removing the SIM card during operation. Also, no guarantee can be given for properly initializing any SIM card that the user inserts after having removed the SIM card during operation. In this case, the application must restart BGS5.*

The figure below shows a circuit to connect an external SIM card holder.

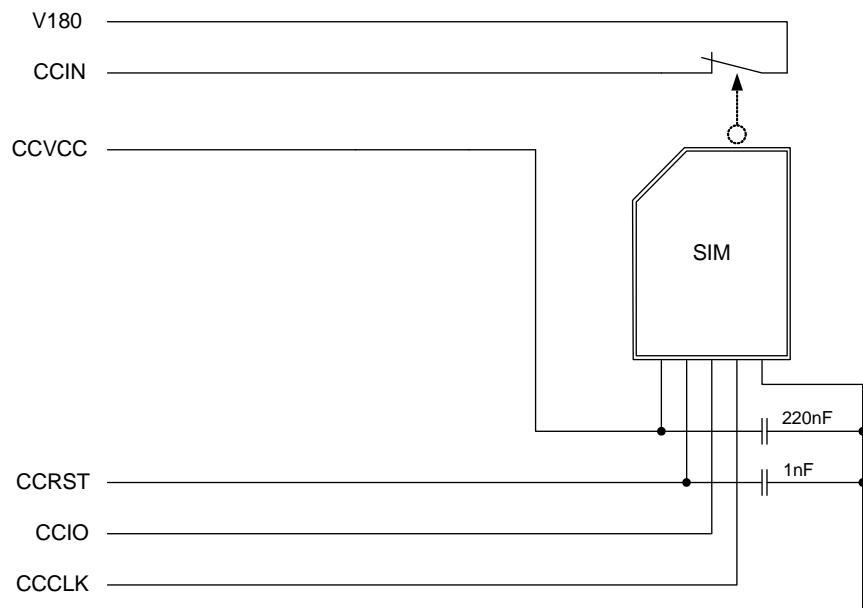

**Figure 9:** External UICC/SIM/USIM card holder circuit

The total cable length between the SMT application interface pads on BGS5 and the pads of the external SIM card holder must not exceed 100mm in order to meet the specifications of 3GPP TS 51.010-1 and to satisfy the requirements of EMC compliance.

To avoid possible cross-talk from the CCCLK signal to the CCIO signal be careful that both lines are not placed closely next to each other. A useful approach is using a GND line to shield the CCIO line from the CCCLK line.

An example for an optimized ESD protection for the SIM interface is shown in [Section 2.1.6.1](#).

### 2.1.6.1 Enhanced ESD Protection for SIM Interface

To optimize ESD protection for the SIM interface it is possible to add ESD diodes to the SIM interface lines as shown in the example given in [Figure 10](#).

The example was designed to meet ESD protection according ETSI EN 301 489-1/7: Contact discharge: ± 4kV, air discharge: ± 8kV.

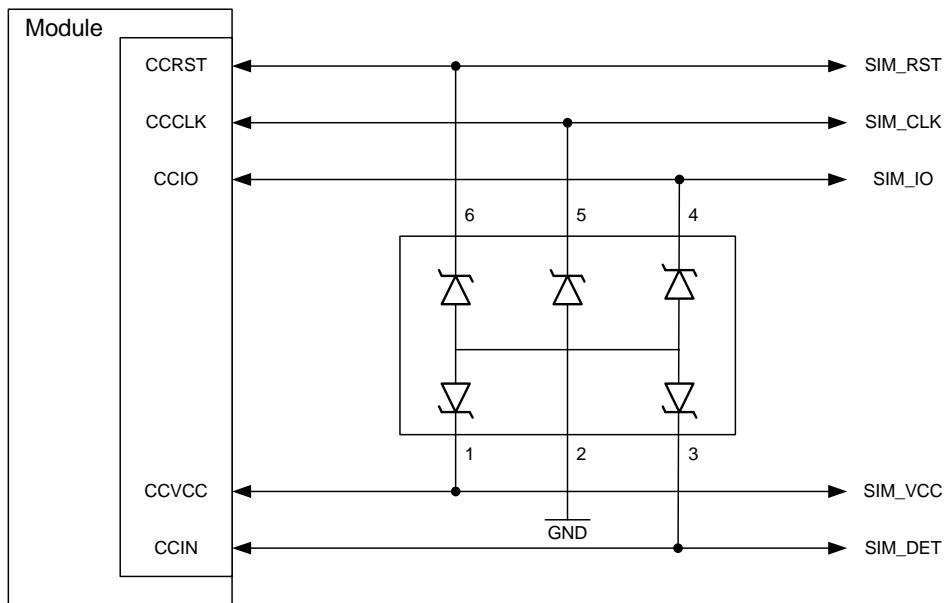

Figure 10: SIM interface - enhanced ESD protection

### 2.1.7 Digital Audio Interface

Four BGS5 GPIO lines can be configured as digital audio interface (DAI). The DAI can be used to connect audio devices capable of pulse code modulation (PCM). The PCM functionality allows for the use of an external codec like the W681360.

The DAI interface supports a 256kHz, long frame synchronization master mode with the following features:

- 16 Bit linear
- 8kHz sample rate
- The most significant bit MSB is transferred first
- 125µs frame duration
- Common frame sync signal for transmit and receive

The four GPIO lines can be configured as DAI/PCM interface signals as follows: GPIO20 --> TXDDAI, GPIO21--> RXDDAI, GPIO22 --> TFSDAI and GPIO23 --> SCLK. The configuration is done by AT command (see [1]). It is non-volatile and becomes active after a module restart. Table 6 describes the available DAI/PCM lines at the digital audio interface. For electrical details see Section 2.1.2.

**Table 6:** Overview of DAI/PCM lines

Signal name	Input/Output	Description
TXDDAI	O	PCM data from BGS5 to external codec.
RXDDAI	I	PCM data from external codec to BGS5.
TFSDAI	O	Frame synchronization signal to external codec: Long frame @ 256kHz
SCLK	O	Bit clock to external codec: 256kHz

Figure 11 shows the PCM timing for the master mode available with BGS5.

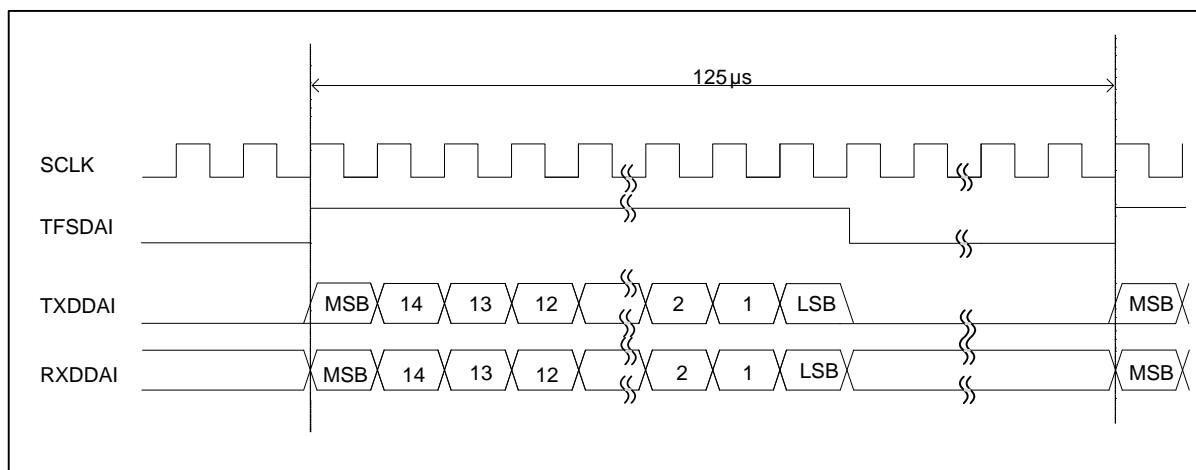

**Figure 11:** Long frame PCM timing, 256kHz

2.1 Application Interface

The following figure shows the start up behaviour of the DAI interface. The start up configuration of functions will be activated after the software initialization of the command interface. With an active state of RING0, CTS0 or CTS1 (low level) the initialization of the DAI interface is finished.

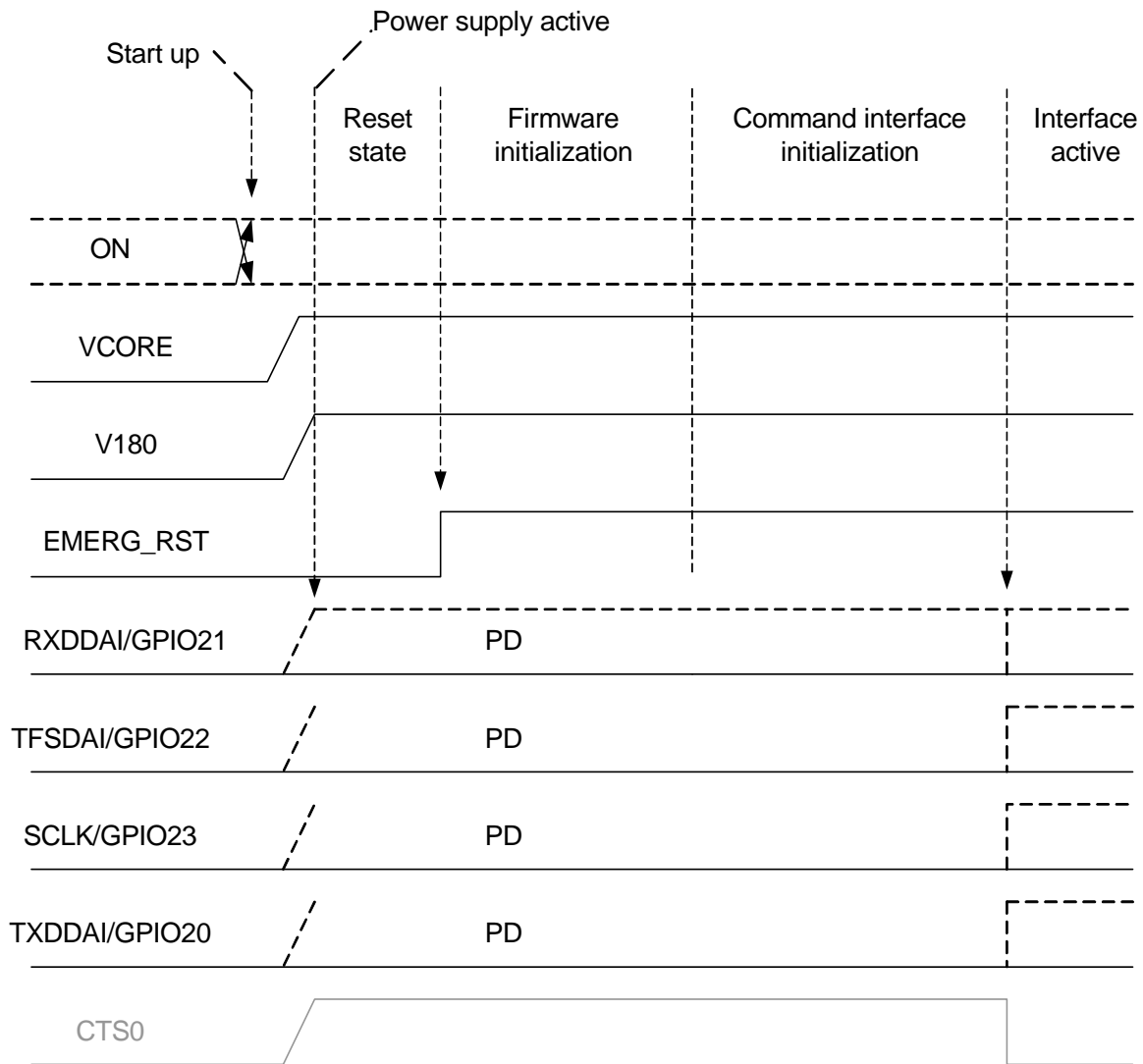

Figure 12: DAI startup timing

### 2.1.8 RTC Backup

The internal Real Time Clock of BGS5 is supplied from a separate voltage regulator in the power supply component which is also active when BGS5 is in Power Down mode and BATT+ is available. An alarm function is provided that allows to wake up BGS5 without logging on to the GSM network.

In addition, you can use the VDDL P pad to backup the RTC from an external capacitor. The capacitor is charged from the internal LDO of BGS5. If the voltage supply at BATT+ is disconnected the RTC can be powered by the capacitor. The size of the capacitor determines the duration of buffering when no voltage is applied to BGS5, i.e. the greater the capacitor the longer BGS5 will save the date and time. The RTC can also be supplied from an external battery (rechargeable or non-chargeable). In this case the electrical specification of the VDDL P pad (see [Section 2.1.2](#)) has to be taken in to account.

[Figure 13](#) shows an RTC backup configuration. A serial 1kOhm resistor has to be placed on the application next to VDDL P. It limits the input current of an empty capacitor or battery.

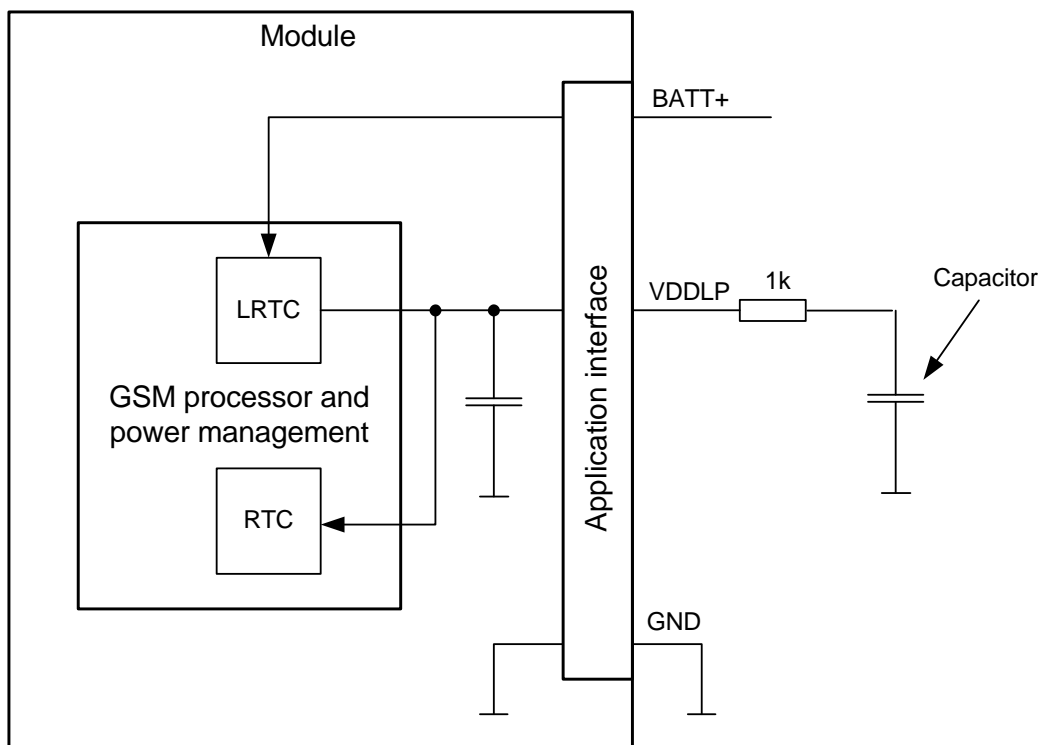

Figure 13: RTC supply variants



## 2.1.9 GPIO Interface

BGS5 offers a GPIO interface with 17 GPIO lines. The GPIO lines are shared with other interfaces resp. functions: Fast shutdown (see [Section 2.1.14.4](#)), status LED (see [Section 2.1.14.1](#)), the PWM functionality (see [Section 2.1.12](#)), a pulse counter (see [Section 2.1.13](#)), ASC0 (see [Section 2.1.4](#)), ASC1 (see [Section 2.1.5](#)), an SPI interface (see [Section 2.1.11](#)) and a PCM interface (see [Section 2.1.7](#))

The following table shows the configuration variants for the GPIO pads. All variants are mutually exclusive, i.e. a pad configured for instance as Status LED is locked for alternative usage.

**Table 7:** GPIO lines and possible alternative assignment

GPIO	Fast Shutdown	Status LED	PWM	Pulse Counter	ASC0	ASC1	SPI	PCM
GPIO1					DTR0			
GPIO2					DCD0			
GPIO3					DSR0			
GPIO4	FST_SHDN							
GPIO5		Status LED						
GPIO6			PWM2					
GPIO7			PWM1					
GPIO8				COUNTER				
GPIO16						RXD1	MOSI	
GPIO17						TXD1	MISO	
GPIO18						RTS1	SPI_CLK	
GPIO19						CTS1	SPI_CS	
GPIO20								TXDDAI
GPIO21								RXDDAI
GPIO22								TFSDAI
GPIO23								SCLK
GPIO24					RING0			

After startup, the above mentioned alternative GPIO line assignments can be configured using AT commands (see [\[1\]](#)). The configuration is non-volatile and available after module restart.

2.1 Application Interface

The following figure shows the startup behavior of the GPIO interface. With an active state of the ASC0 interface (i.e. CTS0 is at low level) the initialization of the GPIO interface lines is also finished.

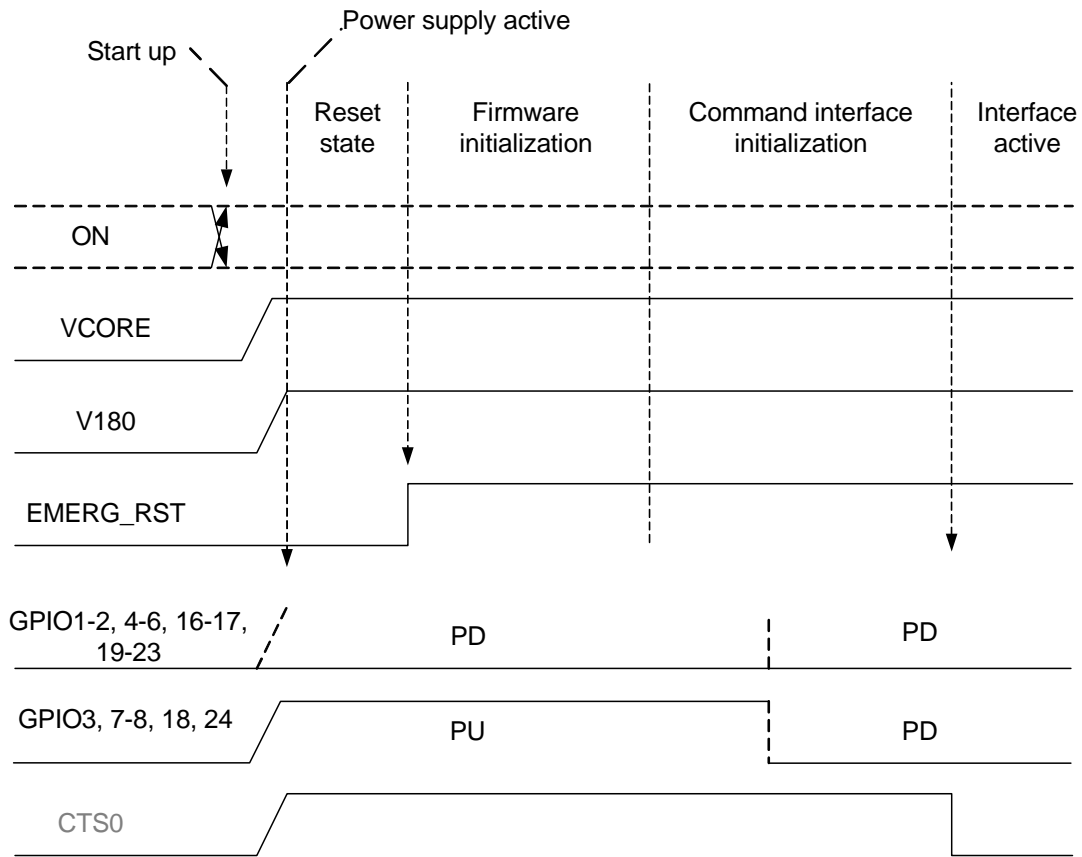

Figure 14: GPIO startup behavior

### 2.1.10 I<sup>2</sup>C Interface

I<sup>2</sup>C is a serial, 8-bit oriented data transfer bus for bit rates up to 400kbps in Fast mode. It consists of two lines, the serial data line I2CDAT and the serial clock line I2CCLK. The module acts as a single master device, e.g. the clock I2CCLK is driven by the module. I2CDAT is a bi-directional line. Each device connected to the bus is software addressable by a unique 7-bit address, and simple master/slave relationships exist at all times. The module operates as master-transmitter or as master-receiver. The customer application transmits or receives data only on request of the module.

To configure and activate the I<sup>2</sup>C bus use the AT<sup>^</sup>SSPI command. Detailed information on the AT<sup>^</sup>SSPI command as well explanations on the protocol and syntax required for data transmission can be found in [1].

The I<sup>2</sup>C interface can be powered via the V180 line of BGS5. If connected to the V180 line, the I<sup>2</sup>C interface will properly shut down when the module enters the Power Down mode.

In the application I2CDAT and I2CCLK lines need to be connected to a positive supply voltage via a pull-up resistor. For electrical characteristics please refer to Table 2.

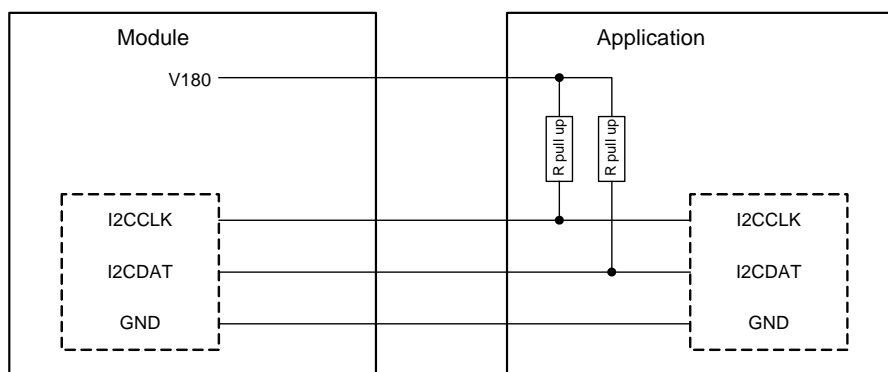

Figure 15: I<sup>2</sup>C interface connected to V180

*Note: Good care should be taken when creating the PCB layout of the host application: The traces of I2CCLK and I2CDAT should be equal in length and as short as possible.*

The following figure shows the startup behavior of the I<sup>2</sup>C interface. With an active state of the ASC0 interface (i.e. CTS0 is at low level) the initialization of the I<sup>2</sup>C interface is also finished.

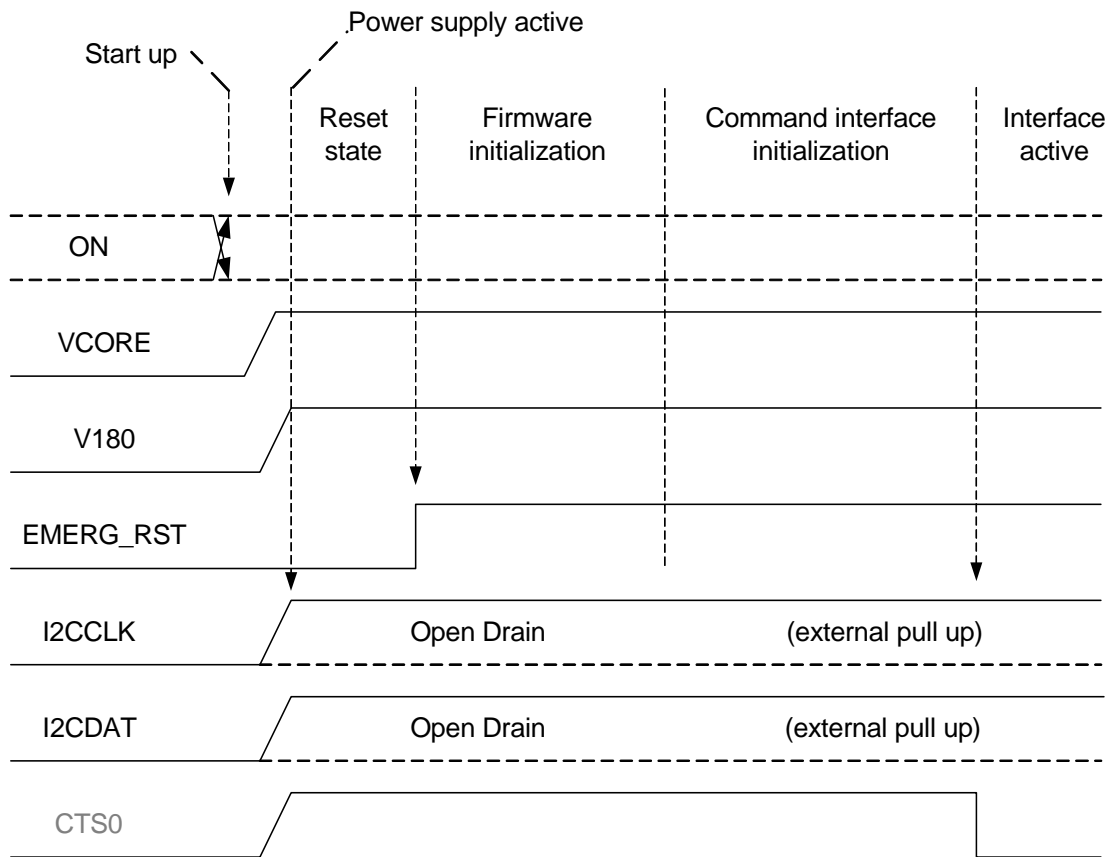

Figure 16: I<sup>2</sup>C startup behavior

### 2.1.11 SPI Interface

Four BGS5 GPIO interface lines can be configured as Serial Peripheral Interface (SPI). The SPI is a synchronous serial interface for control and data transfer between BGS5 and the external application. Only one application can be connected to the SPI and the interface supports only master mode. The transmission rates are up to 6.5Mbit/s. The SPI interface comprises the two data lines MOSI and MISO, the clock line SPI\_CLK a well as the chip select line SPI\_CS.

The four GPIO lines can be configured as SPI interface signals as follows: GPIO16 --> MOSI, GPIO17 --> MISO, GPIO18 --> SPI\_CLK and GPIO19 --> SPI\_CS. The configuration is done by AT command (see [1]). It is non-volatile and becomes active after a module restart.

The GPIO lines are also shared with the ASC1 signal lines.

To configure and activate the SPI interface use the AT^SSPI command. Detailed information on the AT^SSPI command as well explanations on the SPI modes required for data transmission can be found in [1].

In general, SPI supports four operation modes. The modes are different in clock phase and clock polarity. The module's SPI mode can be configured by using the AT command AT^SSPI. Make sure the module and the connected slave device works with the same SPI mode.

Figure 17 shows the characteristics of the four SPI modes. The SPI modes 0 and 3 are the most common used modes. For electrical characteristics please refer to Table 2.

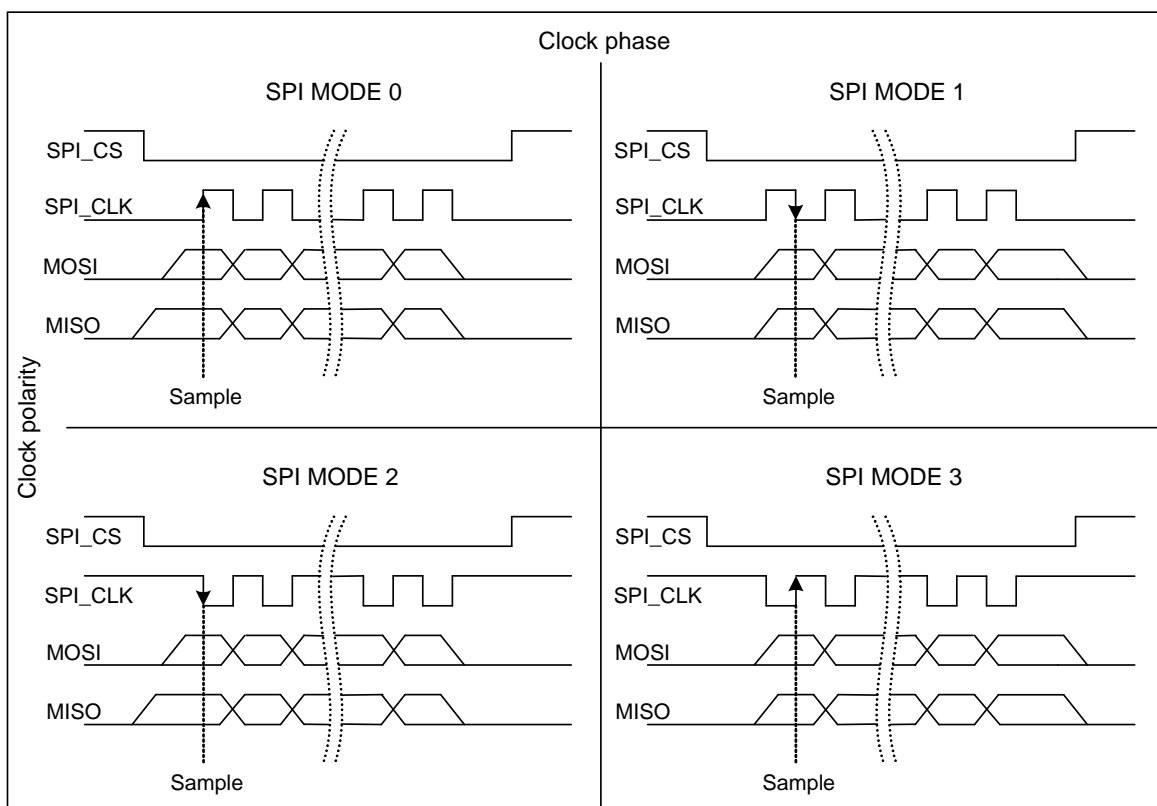

Figure 17: Characteristics of SPI modes

## 2.1.12 PWM Interfaces

The GPIO6 and GPIO7 interface lines can be configured as Pulse Width Modulation (PWM) interface lines PWM1 and PWM2. The PWM interface lines can be used, for example, to connect buzzers. The PWM1 line is shared with GPIO7 and the PWM2 line is shared with GPIO6 (for GPIOs see [Section 2.1.9](#)). GPIO and PWM functionality are mutually exclusive.

The startup behavior of the lines is shown in [Figure 14](#).

## 2.1.13 Pulse Counter

The GPIO8 line can be configured as pulse counter line COUNTER. The pulse counter interface can be used, for example, as a clock (for GPIOs see [Section 2.1.9](#)).

## 2.1.14 Control Signals

### 2.1.14.1 Status LED

The GPIO5 interface line can be configured to drive a status LED that indicates different operating modes of the module (for GPIOs see [Section 2.1.9](#)). GPIO and LED functionality are mutually exclusive.

To take advantage of this function connect an LED to the GPIO5/LED line as shown in [Figure 18](#).

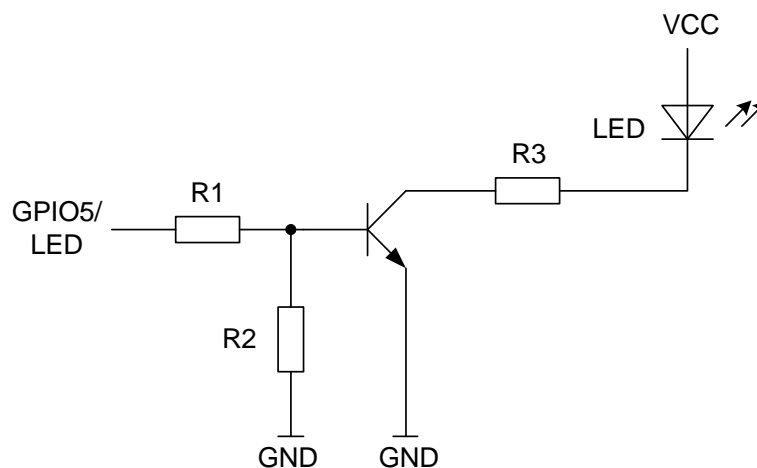

Figure 18: Status signalling with LED driver

### 2.1.14.2 Power Indication Circuit

In Power Down mode the maximum voltage at any digital or analog interface line must not exceed +0.3V (see also [Section 2.1.2.1](#)). Exceeding this limit for any length of time might cause permanent damage to the module.

It is therefore recommended to implement a power indication signal that reports the module's power state and shows whether it is active or in Power Down mode. While the module is in Power Down mode all signals with a high level from an external application need to be set to low state or high impedance state. The sample power indication circuit illustrated in [Figure 19](#) denotes the module's active state with a low signal and the module's Power Down mode with a high signal or high impedance state.

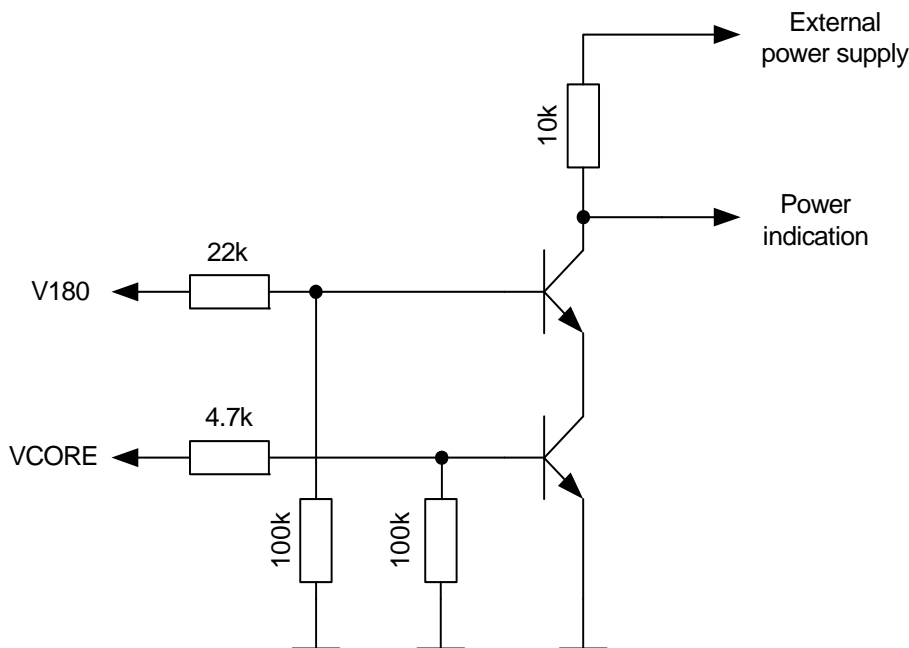

Figure 19: Power indication circuit

### 2.1.14.3 Host Wakeup

If no call, data or message transfer is in progress, the host may shut down its own USB interface to save power. If a call or other request (URC's, messages) arrives, the host can be notified of these events and be woken up again by a state transition of the ASC0 interface's RING0 line.

Possible RING0 line states are listed in [Table 8](#).

Table 8: Host wakeup lines

Signal	I/O	Description
RING0	O	Inactive to active low transition: 0 = The host shall wake up 1 = No wake up request

### 2.1.14.4 Fast Shutdown

The GPIO4 interface line can be configured as fast shutdown signal line FST\_SHDN. The configured FST\_SHDN line is an active low control signal and must be applied for at least 10ms. If unused this line can be left open because of a configured internal pull-up resistor. Before setting the FST\_SHDN line to low, the ON signal should be set to low (see [Figure 20](#)). Otherwise there might be back powering at the ON line in power down mode.

By default, the fast shutdown feature is disabled. It has to be enabled using the AT command `AT^SCFG "MEShutdown/Fso"`. For details see [\[1\]](#).

If enabled, a low impulse >10ms on the GPIO4/FST\_SHDN line starts the fast shutdown (see [Figure 20](#)). The fast shutdown procedure still finishes any data activities on the module's flash file system, thus ensuring data integrity, but will no longer deregister gracefully from the network, thus saving the time required for network deregistration.

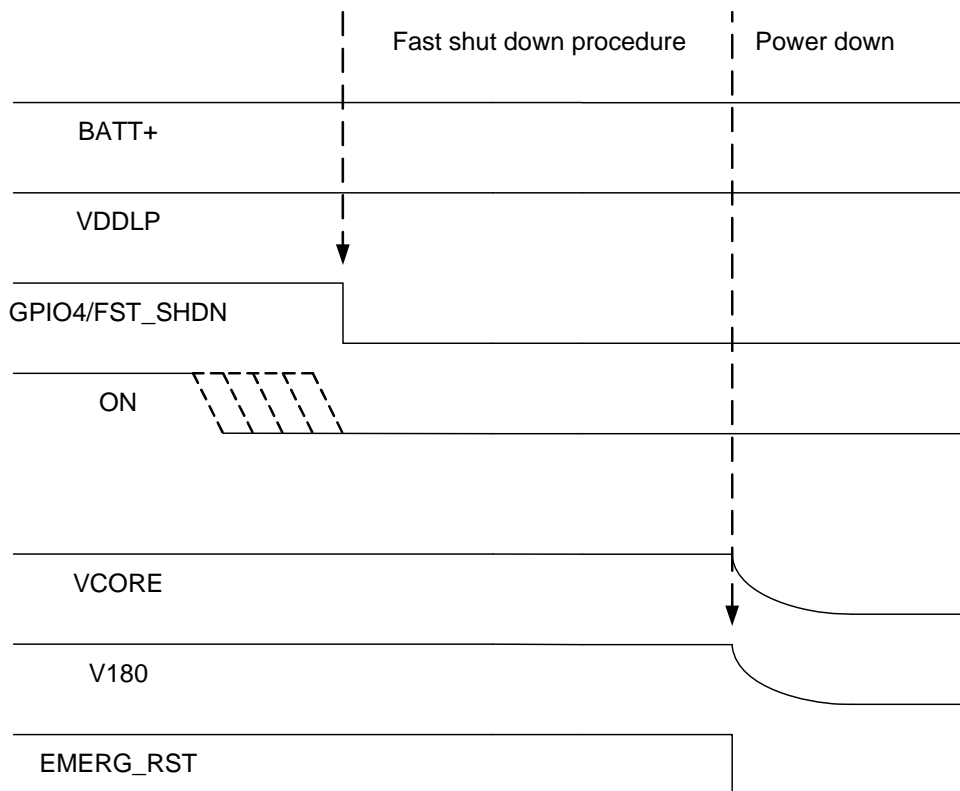

**Figure 20:** Fast shutdown timing

Please note that if enabled, the normal software controlled shutdown using `AT^SMSO` will also be a fast shutdown, i.e., without network deregistration. However, in this case no URCs including shutdown URCs will be provided by the `AT^SMSO` command.



## 2.2 RF Antenna Interface

The RF interface has an impedance of 50Ω. BGS5 is capable of sustaining a total mismatch at the antenna line without any damage, even when transmitting at maximum RF power.

The external antenna must be matched properly to achieve best performance regarding radiated power, modulation accuracy and harmonic suppression. Antenna matching networks are not included on the BGS5 module and should be placed in the host application if the antenna does not have an impedance of 50Ω.

Regarding the return loss BGS5 provides the following values in the active band:

**Table 9:** Return loss in the active band

State of module	Return loss of module	Recommended return loss of application
Receive	≥ 8dB	≥ 12dB
Transmit	not applicable	≥ 12dB

### 2.2.1 Antenna Interface Specifications

**Table 10:** RF Antenna interface GSM

Parameter	Conditions	Min.	Typical	Max.	Unit	
GPRS coding schemes	Class 12, CS1 to CS4					
GSM Class	Small MS					
Static Receiver input Sensitivity @ ARP	GSM 850 / E-GSM 900		-109		dBm	
	GSM 1800 / GSM 1900		-109		dBm	
RF Power @ ARP with 50Ohm Load	GSM 850 / E-GSM 900		33		dBm	
	GSM 1800 / GSM 1900		30		dBm	
RF Power @ ARP with 50Ohm Load, (ROPR = 0, i.e. no reduction)	GPRS, 1 TX	GSM 850 / E-GSM 900		32.9		dBm
		GSM 1800 / GSM 1900		30.1		dBm
	GPRS, 2 TX	GSM 850 / E-GSM 900		32.9		dBm
		GSM 1800 / GSM 1900		30.1		dBm
	GPRS, 3 TX	GSM 850 / E-GSM 900		32.9		dBm
		GSM 1800 / GSM 1900		30.1		dBm
	GPRS, 4 TX	GSM 850 / E-GSM 900		32.9		dBm
		GSM 1800 / GSM 1900		30.1		dBm

## 2.2 RF Antenna Interface

Table 10: RF Antenna interface GSM

Parameter		Conditions	Min.	Typical	Max.	Unit
RF Power @ ARP with 50Ohm Load, (ROPR = 1)	GPRS, 1 TX	GSM 850 / E-GSM 900		32.9		dBm
		GSM 1800 / GSM 1900		30.1		dBm
	GPRS, 2 TX	GSM 850 / E-GSM 900		32.9		dBm
		GSM 1800 / GSM 1900		30.1		dBm
	GPRS, 3 TX	GSM 850 / E-GSM 900		31.7		dBm
		GSM 1800 / GSM 1900		29.7		dBm
GPRS, 4 TX	GSM 850 / E-GSM 900		30		dBm	
	GSM 1800 / GSM 1900		28.6		dBm	
RF Power @ ARP with 50Ohm Load, (ROPR = 2)	GPRS, 1 TX	GSM 850 / E-GSM 900		33		dBm
		GSM 1800 / GSM 1900		30.1		dBm
	GPRS, 2 TX	GSM 850 / E-GSM 900		31.6		dBm
		GSM 1800 / GSM 1900		29.3		dBm
	GPRS, 3 TX	GSM 850 / E-GSM 900		30.1		dBm
		GSM 1800 / GSM 1900		28.1		dBm
GPRS, 4 TX	GSM 850 / E-GSM 900		27.3		dBm	
	GSM 1800 / GSM 1900		27.2		dBm	
RF Power @ ARP with 50Ohm Load, (ROPR = 3)	GPRS, 1 TX	GSM 850 / E-GSM 900		33		dBm
		GSM 1800 / GSM 1900		30.1		dBm
	GPRS, 2 TX	GSM 850 / E-GSM 900		29.8		dBm
		GSM 1800 / GSM 1900		28.3		dBm
	GPRS, 3 TX	GSM 850 / E-GSM 900		27.7		dBm
		GSM 1800 / GSM 1900		27.4		dBm
GPRS, 4 TX	GSM 850 / E-GSM 900		25.4		dBm	
	GSM 1800 / GSM 1900		25.2		dBm	
RF Power @ ARP with 50Ohm Load, (ROPR = 4, i.e. maximum reduction)	GPRS, 1 TX	GSM 850 / E-GSM 900		33		dBm
		GSM 1800 / GSM 1900		30.1		dBm
	GPRS, 2 TX	GSM 850 / E-GSM 900		29.8		dBm
		GSM 1800 / GSM 1900		28.3		dBm
	GPRS, 3 TX	GSM 850 / E-GSM 900		27.7		dBm
		GSM 1800 / GSM 1900		27.4		dBm
GPRS, 4 TX	GSM 850 / E-GSM 900		25.4		dBm	
	GSM 1800 / GSM 1900		25.2		dBm	

## 2.2.2 Antenna Installation

The antenna is connected by soldering the antenna pad (RF\_OUT, i.e., pad #59) and its neighboring ground pads (GND, i.e., pads #58 and #60) directly to the application's PCB. The antenna pad is the antenna reference point (ARP) for BGS5. All RF data specified throughout this document is related to the ARP.

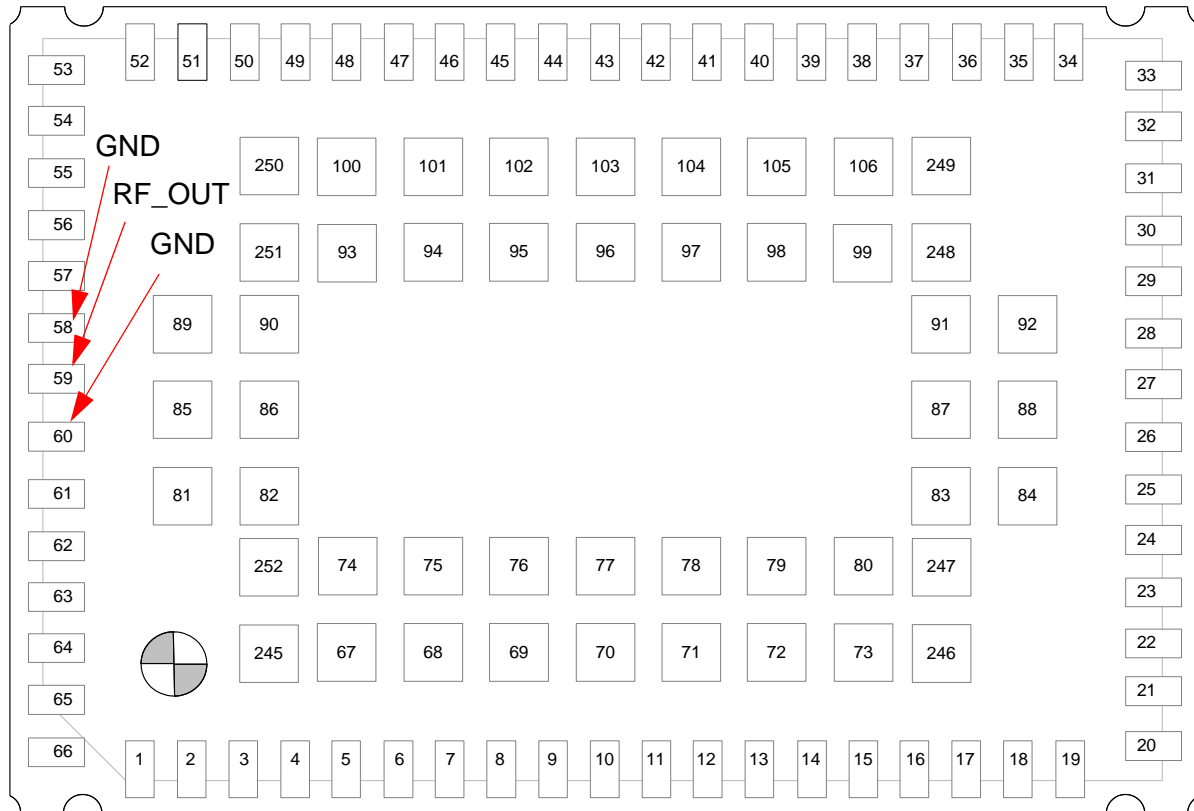

**Figure 21:** Antenna pads (bottom view)

The distance between the antenna RF\_OUT pad (#59) and its neighboring GND pads (#58, #60) has been optimized for best possible impedance. On the application PCB, special attention should be paid to these 3 pads, in order to prevent mismatch.

The wiring of the antenna connection line, starting from the antenna pad to the application antenna should result in a  $50\Omega$  line impedance. Line width and distance to the GND plane needs to be optimized with regard to the PCB's layer stack. Some examples are given in [Section 2.2.3](#).

To prevent receiver desensitization due to interferences generated by fast transients like high speed clocks on the application PCB, it is recommended to realize the antenna connection line using embedded Stripline rather than Micro-Stripline technology. Please see [Section 2.2.3.1](#) for an example.

For type approval purposes, the use of a  $50\Omega$  coaxial antenna connector (U.FL-R-SMT) might be necessary. In this case the U.FL-R-SMT connector should be placed as close as possible to BGS5's antenna pad.

## 2.2.3 RF Line Routing Design

### 2.2.3.1 Line Arrangement Examples

Several dedicated tools are available to calculate line arrangements for specific applications and PCB materials - for example from <http://www.polarinstruments.com/> (commercial software) or from <http://web.awrcorp.com/Usa/Products/Optional-Products/TX-Line/> (free software).

#### Embedded Stripline

The figure below shows a line arrangement example for embedded stripline on a 0.8mm standard FR4 PCB.

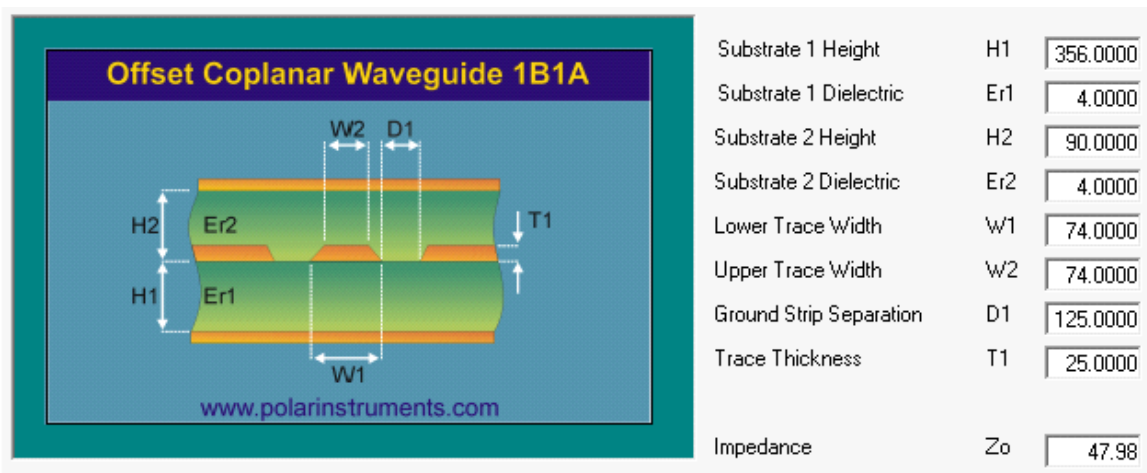

Figure 22: Embedded Stripline on a 0.8mm standard FR4 PCB

#### Micro-Stripline

The figure below shows a line arrangement example for micro-stripline on a 0.8mm standard FR4 PCB.

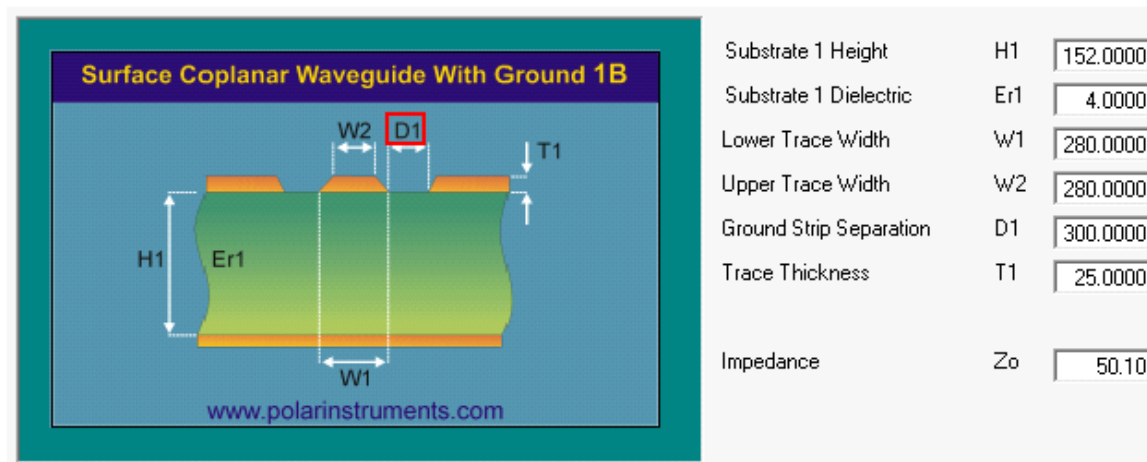

Figure 23: Micro-Stripline on a 0.8mm standard FR4 PCB

### Differential 150Ohm Lines

The figure below shows a line arrangement example for differential 150Ohm lines on a 0.8mm standard FR4 PCB.

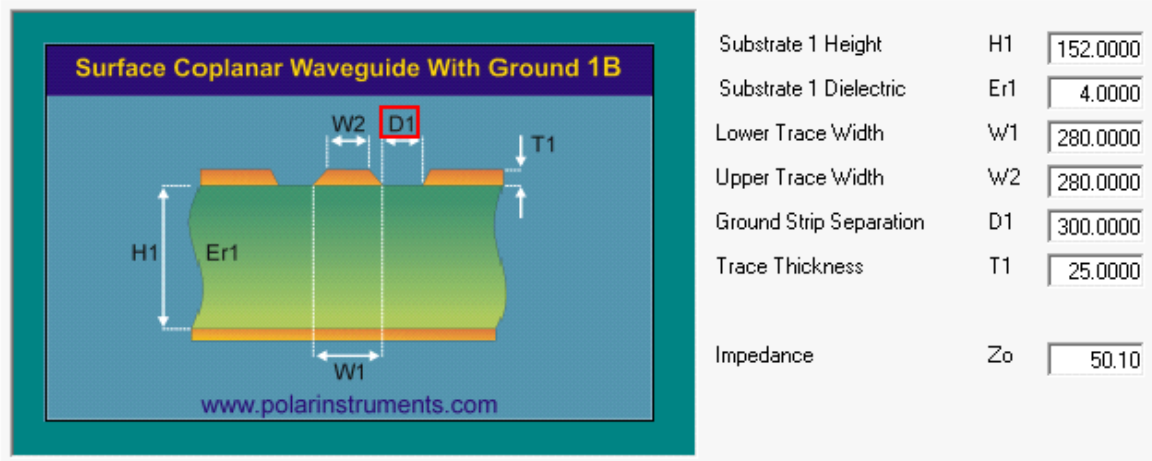

Figure 24: Differential 150Ohm lines on a 0.8mm standard FR4 PCB

### 2.2.3.2 Routing Example

#### Interface to RF Connector

Figure 25 shows the connection of the module's antenna pad with an application PCB's coaxial antenna connector. Please note that the BGS5 bottom plane appears mirrored, since it is viewed from BGS5 top side. By definition the top of customer's board shall mate with the bottom of the BGS5 module.

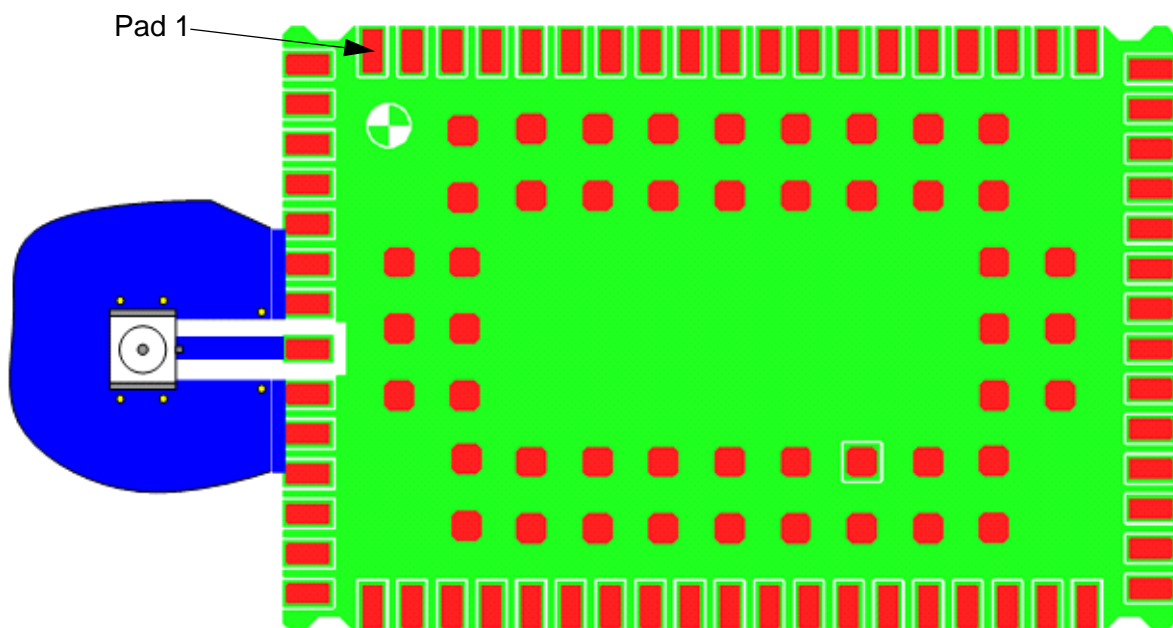

Figure 25: Routing to application's RF connector - top view

## 2.3 Sample Application

Figure 26 shows a typical example of how to integrate a BGS5 module with an application. Usage of the various host interfaces depends on the desired features of the application.

Because of the very low power consumption design, current flowing from any other source into the module circuit must be avoided, for example reverse current from high state external control lines. Therefore, the controlling application must be designed to prevent reverse current flow. Otherwise there is the risk of undefined states of the module during startup and shutdown or even of damaging the module.

Because of the high RF field density inside the module, it cannot be guaranteed that no self interference might occur, depending on frequency and the applications grounding concept. excluded that in some applications dependant on the grounding concept of the customer. The potential interferers may be minimized by placing small capacitors (47pF) at suspected lines (e.g. RXD0, VDDL, and ON).

**While developing SMT applications it is strongly recommended to provide test points for certain signals resp. lines to and from the module - for debug and/or test purposes. The SMT application should allow for an easy access to these signals. For details on how to implement test points see [3].**

The EMC measures are best practice recommendations. In fact, an adequate EMC strategy for an individual application is very much determined by the overall layout and, especially, the position of components. For example, mounting the internal acoustic transducers directly on the PCB eliminates the need to use the ferrite beads shown in the sample schematic.

Depending on the micro controller used by an external application BGS5's digital input and output lines may require level conversion. Section 2.3.1 shows a possible sample level conversion circuit.

Please note that BGS5 is not intended for use with cables longer than 3m.

### Disclaimer

No warranty, either stated or implied, is provided on the sample schematic diagram shown in Figure 26 and the information detailed in this section. As functionality and compliance with national regulations depend to a great amount on the used electronic components and the individual application layout manufacturers are required to ensure adequate design and operating safeguards for their products using BGS5 modules.

2.3 Sample Application

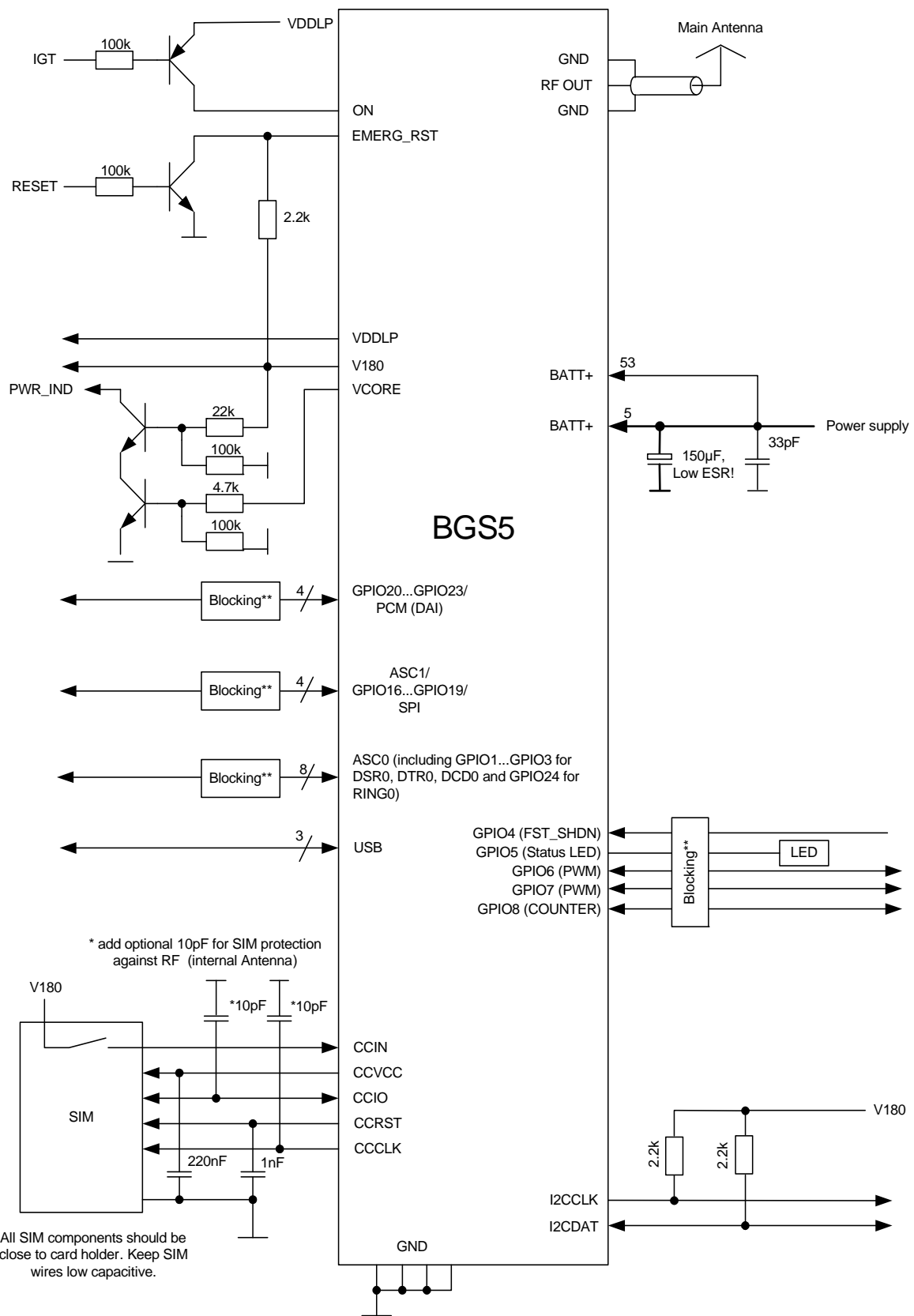

Blocking\*\* = For more details see [Section 3.6.2](#)

Figure 26: Schematic diagram of BGS5 sample application

### 2.3.1 Sample Level Conversion Circuit

Depending on the micro controller used by an external application BGS5's digital input and output lines (i.e., ASC0, ASC1 and GPIO lines) may require level conversion. The following [Figure 27](#) shows a sample circuit with recommended level shifters for an external application's micro controller (with VLOGIC between 3.0V...3.6V). The level shifters can be used for digital input and output lines with  $V_{OH,max}=1.85V$  or  $V_{IH,max}=1.85V$ .

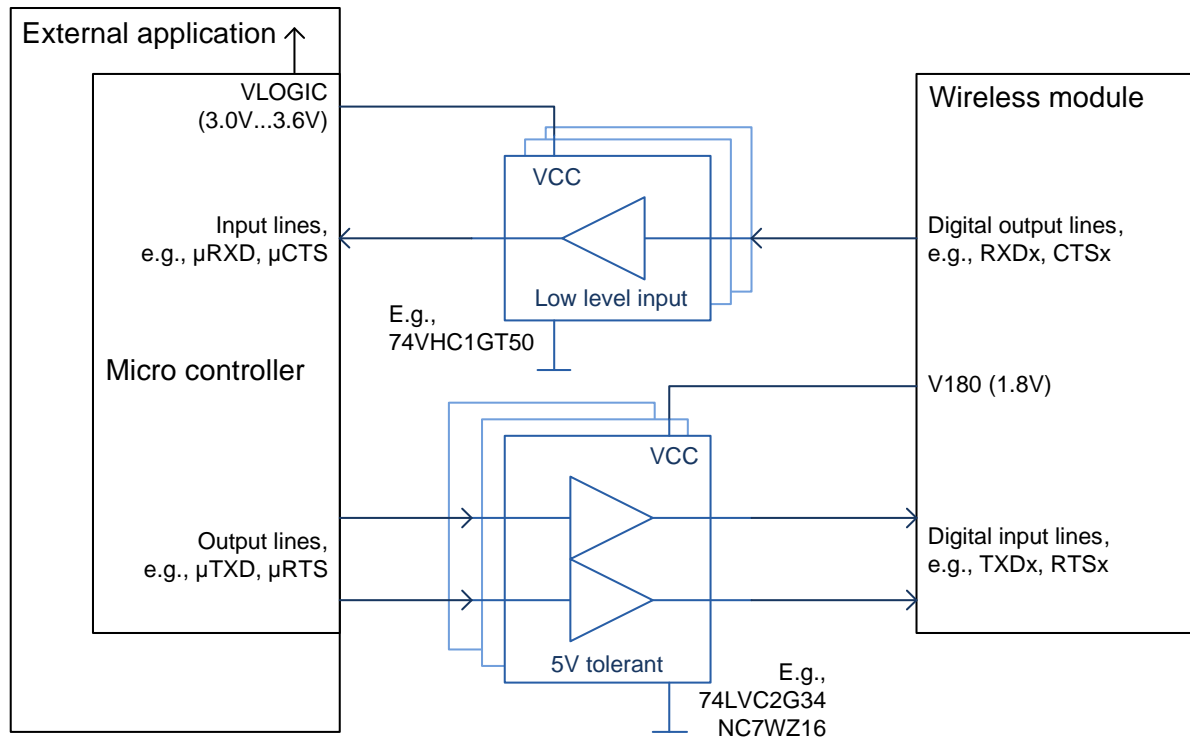

**Figure 27:** Sample level conversion circuit



## 3 Operating Characteristics

### 3.1 Operating Modes

The table below briefly summarizes the various operating modes referred to throughout the document.

**Table 11:** Overview of operating modes

Mode	Function	
Normal operation	GSM / GPRS SLEEP	No call is in progress and the USB connection is suspended by host (or is not present) and no active communication via ASC0. For power saving issues see <a href="#">Section 3.3</a> .
	GSM / GPRS IDLE	No call is in progress and the USB connection is not suspended by host (or is not present) and no active communication via ASC0. For power saving issues see <a href="#">Section 3.3</a> .
	GSM TALK/ GSM DATA	Connection between two subscribers is in progress. Power consumption depends on the GSM network coverage and several connection settings (e.g. DTX off/on, FR/EFR/HR, hopping sequences and antenna connection). The following applies when power is to be measured in TALK_GSM mode: DTX off, FR and no frequency hopping.
	GPRS DATA	GPRS data transfer in progress. Power consumption depends on network settings (e.g. power control level), uplink / downlink data rates and GPRS configuration (e.g. used multislot settings).
Power Down	Normal shutdown after sending the power down command. Only a voltage regulator is active for powering the RTC. Software is not active. Interfaces are not accessible. Operating voltage (connected to BATT+) remains applied.	
Airplane mode	Airplane mode shuts down the radio part of the module, causes the module to log off from the GSM/GPRS network and disables all AT commands whose execution requires a radio connection. Airplane mode can be controlled by AT command (see <a href="#">[1]</a> ).	

## 3.2 Power Up/Power Down Scenarios

In general, be sure not to turn on BGS5 while it is beyond the safety limits of voltage and temperature stated in [Section 2.1.2.1](#). BGS5 would immediately switch off after having started and detected these inappropriate conditions. In extreme cases this can cause permanent damage to the module.

### 3.2.1 Turn on BGS5

BGS5 can be started into Normal mode as described below in [Section 3.2.1.1](#). After startup or restart, the module will send the URC ^SYSSTART that notifies the host application that the first AT command can be sent to the module (see also [\[1\]](#)).

#### 3.2.1.1 Switch on BGS5 Using ON Signal

When the operating voltage BATT+ is applied, BGS5 can be switched on by means of the ON signal.

The ON signal is an edge triggered signal and only allows the input voltage level of the VDDL P signal. The module starts into normal mode on detecting the rising edge of the ON signal.

The following [Figure 28](#) shows an example for a switch-on circuit.

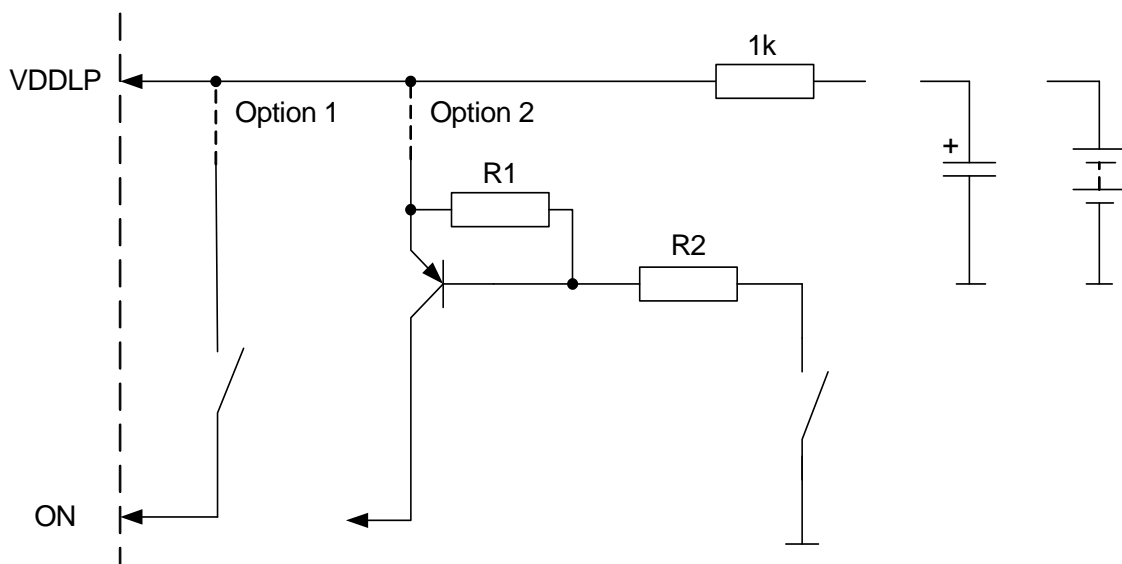

Figure 28: ON circuit sample

It is recommended to set a serial 1kOhm resistor between the ON circuit and the external capacitor or battery at the VDDL P power supply. This serial resistor protection is necessary in case the capacitor or battery has low power (is empty). Typical values for the resistors shown in [Figure 28](#) for Option 2 are R1=150k and R2=22k, depending on the current gain of the employed PNP transistor.

## 3.2 Power Up/Power Down Scenarios

Please note that the ON signal is an edge triggered signal. This implies that a micro-seconds high pulse on the signal line suffices to almost immediately switch on the module, as shown in [Figure 29](#). After module startup the ON signal should always be set to low to prevent possible back powering at this pin.

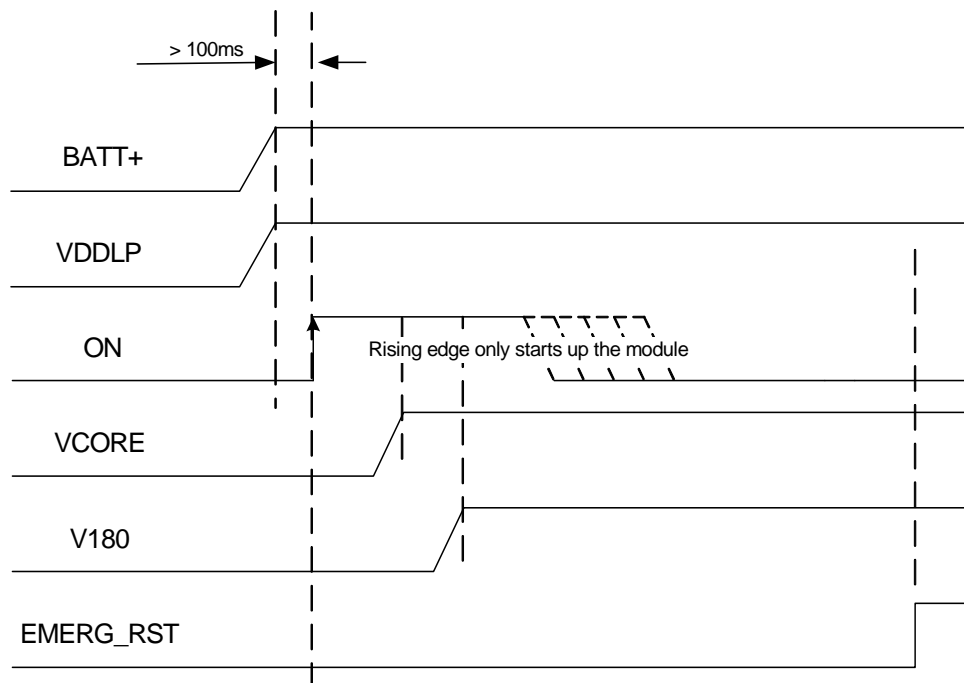

Figure 29: ON timing

### 3.2.2 Restart BGS5

After startup BGS5 can be re-started as described in the following sections:

- Software controlled reset by AT+CFUN command: Starts Normal mode (see [Section 3.2.2.1](#)).
- Hardware controlled reset by EMERG\_RST line: Starts Normal mode (see [Section 3.2.2.2](#))

#### 3.2.2.1 Restart BGS5 via AT+CFUN Command

To reset and restart the BGS5 module use the command AT+CFUN. See [\[1\]](#) for details.

### 3.2.2.2 Restart BGS5 Using EMERG\_RST

The EMERG\_RST signal is internally connected to the central GSM processor. A low level for more than 10ms sets the processor and with it all the other signal pads to their respective reset state. The reset state is described in [Section 3.2.3](#) as well as in the figures showing the startup behavior of an interface.

After releasing the EMERG-RST line, i.e., with a change of the signal level from low to high, the module restarts. The other signals continue from their reset state as if the module was switched on by the ON signal.

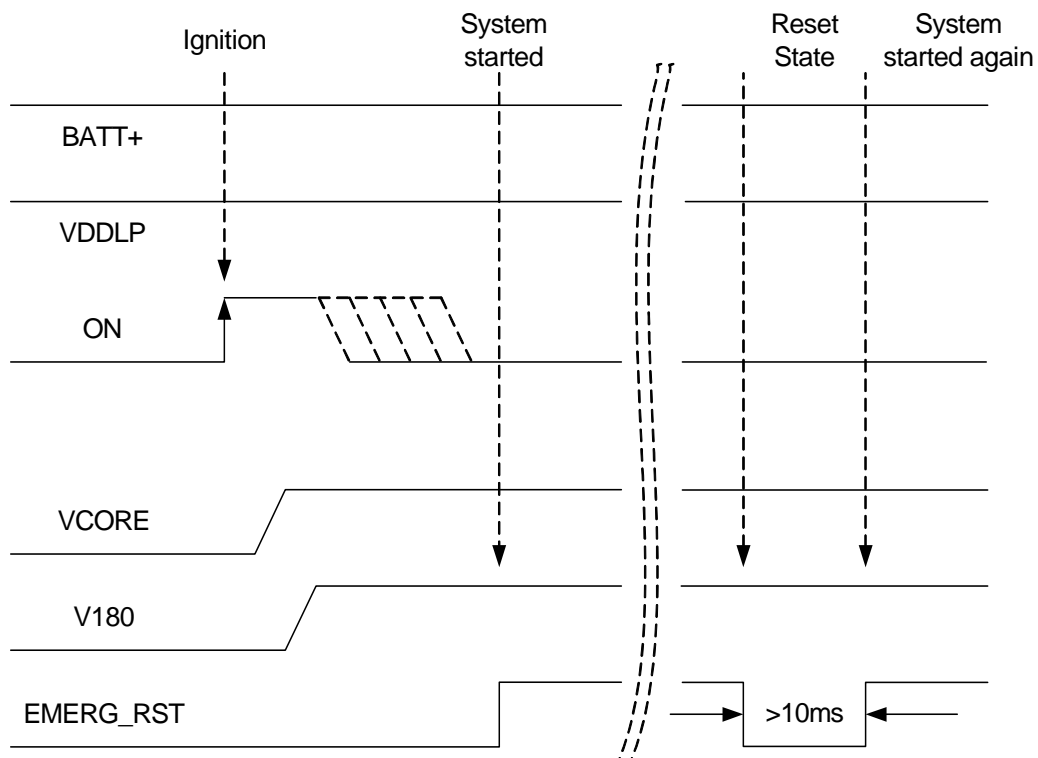

Figure 30: Emergency restart timing

The EMERG\_RST line must always be connected to V180 with a 2.2KOhm pull-up resistor. It is recommended to control the EMERG\_RST line with an open collector transistor or an open drain field-effect transistor.

*Caution: Use the EMERG\_RST line only when, due to serious problems, the software is not responding for more than 5 seconds. Pulling the EMERG\_RST line causes the loss of all information stored in the volatile memory. Therefore, this procedure is intended only for use in case of emergency, e.g. if BGS5 does not respond, if reset or shutdown via AT command fails.*

### 3.2.3 Signal States after Startup

Table 12 lists the states each interface signal passes through during reset and firmware initialization if the GPIO signal lines are configured as shown below. For possible further GPIO signal configurations other firmware startup signal states may apply. The possible GPIO signal configuration variants are given in brackets.

The reset state is reached with the rising edge of the EMERG\_RST signal - either after a normal module startup (see Section 3.2.1.1) or after a reset (see Section 3.2.2.2). After the reset state has been reached the firmware initialization state begins. The firmware initialization is completed as soon as the ASC0 interface line CTS0 has turned low (see Section 2.1.4). Now, the module is ready to receive and transmit data.

Table 12: Signal states

Signal name	Reset state	First start up configuration
CCIO	L	O / L
CCRST	L	O / L
CCCLK	L	O / L
CCIN	T / PD	I / 100k PD
RXD0	T / PU	O / H
TXD0	T / PD	I
CTS0	T / PD	O / H
RTS0	T / PU	I / PD
DTR0 (GPIO1)	T / PD	I
DCD0 (GPIO2)	T / PD	O / H
DSR0 (GPIO3 / SPI_CLK)	T / PU	O / H
FST_SHDN (GPIO4)	T / PD	T / PD
GPIO5 (Status LED)	T / PD	T / PD
GPIO6 (PWM2)	T / PD	T / PD
GPIO7 (PWM1)	T / PU	T / PD
GPIO8 (COUNTER)	T / PU	T / PD
RXD1 (GPIO16 / MOSI)	T / PD	T / PD
TXD1 (GPIO17 / MISO)	T / PD	T / PD
RTS1 (GPIO18 / SPI_CLK)	T / PU	T / PD
CTS1 (GPIO19 / SPI_CS)	T / PD	T / PD
TXDDAI (GPIO20)	T / PD	T / PD
RXDDAI (GPIO21)	T / PD	T / PD
TFSDAI (GPIO22)	T / PD	T / PD
SCLK (GPIO23)	T / PD	T / PD
RING0 (GPIO24)	T / PU	O / H
I2CCLK	T	T / OD
I2CDAT	T	T / OD

Abbreviations used in above Table 12:

L = Low level H = High level T = Tristate I = Input	O = Output OD = Open Drain PD = Pull down, +170µA at 1.85V PU = Pull up, -220µA at 0V
--	--

### 3.2.4 Turn off BGS5

To switch the module off the following procedures may be used:

- *Normal shutdown procedure:* Software controlled by sending an AT command over the serial application interface. See [Section 3.2.4.1](#).
- *Automatic shutdown:* See [Section 3.2.5](#)
  - Takes effect if under- or overvoltage is detected.
  - Takes effect if BGS5 board temperature exceeds a critical limit.

#### 3.2.4.1 Switch off BGS5 Using AT Command

The best and safest approach to powering down BGS5 is to issue the appropriate AT command. This procedure lets BGS5 log off from the network and allows the software to enter into a secure state and save data before disconnecting the power supply. The mode is referred to as Power Down mode. In this mode, only the RTC stays active. Before issuing the switch off AT command, the ON signal should be set to low (see [Figure 31](#)). Otherwise there might be back powering at the ON line in power down mode.

Be sure not to disconnect the operating voltage  $V_{BATT+}$  before V180 pad has gone low. Otherwise you run the risk of losing data.

While BGS5 is in Power Down mode the application interface is switched off and must not be fed from any other voltage source. Therefore, your application must be designed to avoid any current flow into any digital pads of the application interface.

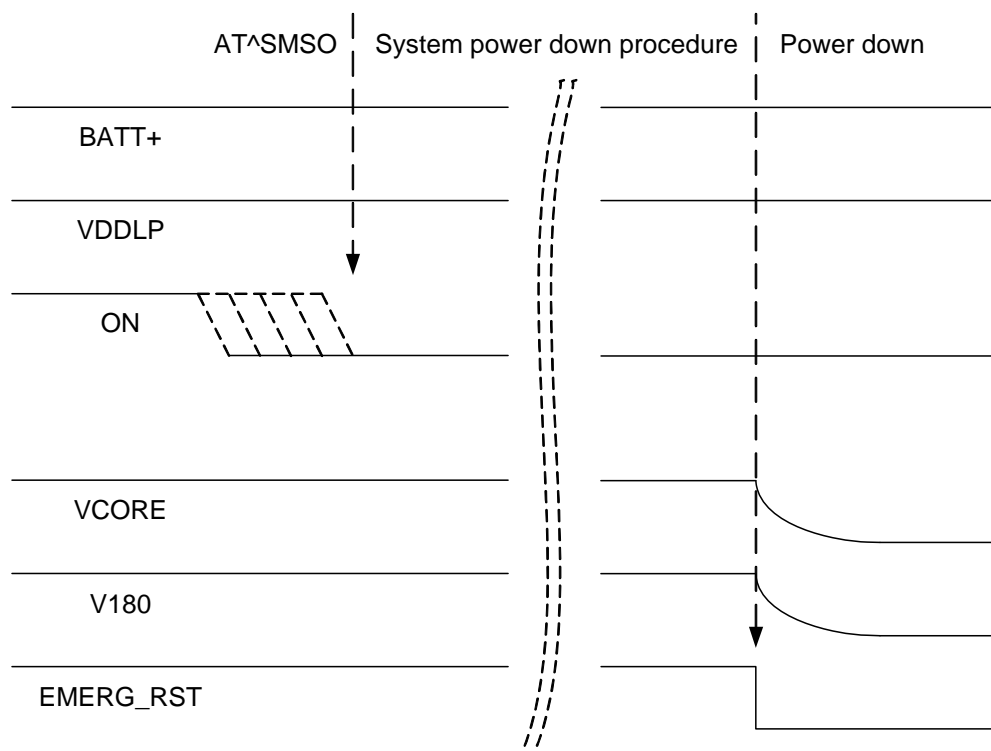

Figure 31: Switch off behavior

### 3.2.4.2 Disconnect BGS5 BATT+ Lines

Figure 32 shows an external application circuit that provides the possibility to temporarily (>100ms) disconnect the module's BATT+ lines from the external application's power supply. The mentioned MOSFET transistor (T8) should have an  $R_{DS\_ON}$  value  $\leq 50m\Omega$  in order to minimize voltage drops. Such a circuit could be useful to maximize power savings for battery driven applications or to completely switch off and restart the module after a firmware update.

Afterwards the module can be restarted as described in Section 3.2.1.

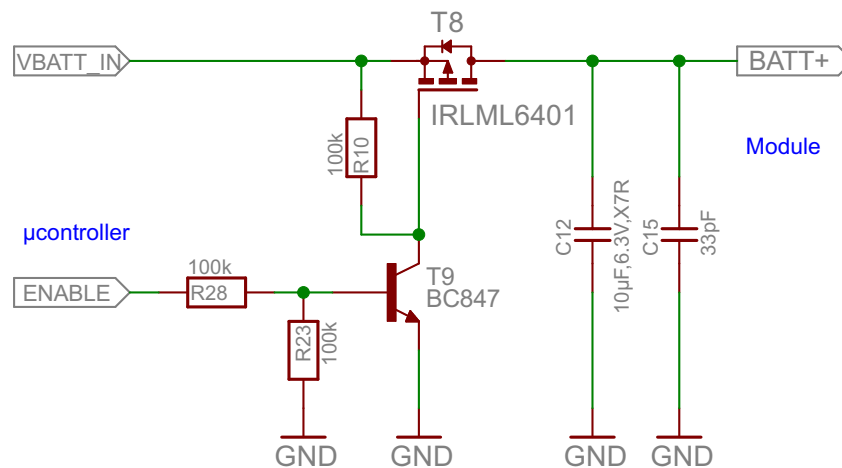

Figure 32: Restart circuit using BATT+ line

### 3.2.5 Automatic Shutdown

Automatic shutdown takes effect if any of the following events occurs:

- The BGS5 board is exceeding the critical limits of overtemperature or undertemperature

The automatic shutdown procedure is equivalent to the power-down initiated with an AT command, i.e. BGS5 logs off from the network and the software enters a secure state avoiding loss of data.

#### 3.2.5.1 Thermal Shutdown

The board temperature is constantly monitored by an internal NTC resistor located on the PCB. The values detected by the NTC resistor are measured directly on the board and therefore, are not fully identical with the ambient temperature.

The board temperature is constantly monitored by an internal NTC resistor located on the PCB. The values detected by the NTC resistor are measured directly on the board and therefore, are not fully identical with the ambient temperature.

Each time the board temperature goes out of range or back to normal, BGS5 instantly displays an alert (if enabled).

- URCs indicating the level "1" or "-1" allow the user to take appropriate precautions, such as protecting the module from exposure to extreme conditions. The presentation of the URCs depends on the settings selected with the AT^SCTM write command (for details see [1]):  
AT^SCTM=1: Presentation of URCs is always enabled.  
AT^SCTM=0 (default): Presentation of URCs is enabled during the 2 minute guard period after start-up of BGS5. After expiry of the 2 minute guard period, the presentation of URCs will be disabled, i.e. no URCs with alert levels "1" or "-1" will be generated.
- URCs indicating the level "2" or "-2" are instantly followed by an orderly shutdown. The presentation of these URCs is always enabled, i.e. they will be output even though the factory setting AT^SCTM=0 was never changed.

The maximum temperature ratings are stated in [Section 5.2](#). Refer to [Table 13](#) for the associated URCs.

**Table 13:** Temperature dependent behavior

Sending temperature alert (2min after module start-up, otherwise only if URC presentation enabled)	
^SCTM_B: 1	Board close to overtemperature limit.
^SCTM_B: -1	Board close to undertemperature limit.
^SCTM_B: 0	Board back to non-critical temperature range.
Automatic shutdown (URC appears no matter whether or not presentation was enabled)	
^SCTM_B: 2	Alert: Board equal or beyond overtemperature limit. BGS5 switches off.
^SCTM_B: -2	Alert: Board equal or below undertemperature limit. BGS5 switches off.



### 3.3 Power Saving

BGS5 can be configured in two ways to control power consumption:

- Using the AT command `AT^SPOW` it is possible to specify a so-called power saving mode for the module (`<mode> = 2`; for details on the command see [1]). The module's UART interfaces (ASC0 and ASC1) are then deactivated and will only periodically be activated to be able to listen to network paging messages as described in Section 3.3.1. Please note that the `AT^SPOW` setting has no effect on USB interface. As long as the `VUSB_IN` is set to high, the module will not change into SLEEP mode to reduce its functionality to a minimum and thus minimizing its current consumption. To enable switching into SLEEP mode, the USB connection must therefore either not be present at all or the USB host must disable the `VUSB_IN` output.
- Using the AT command `AT^SCFG="Radio/OutputPowerReduction"` it is possible for the module in GPRS multislots scenarios to reduce its output power according to 3GPP 45.005 section. By default a maximum power reduction is enabled. For details on the command see [1].

#### 3.3.1 Power Saving while Attached to GSM Networks

The power saving possibilities while attached to a GSM network depend on the paging timing cycle of the base station. The duration of a power saving interval can be calculated using the following formula:

$$t = 4.615 \text{ ms (TDMA frame duration)} * 51 \text{ (number of frames)} * \text{DRX value.}$$

DRX (Discontinuous Reception) is a value from 2 to 9, resulting in paging intervals between 0.47 and 2.12 seconds. The DRX value of the base station is assigned by the GSM network operator.

In the pauses between listening to paging messages, the module resumes power saving, as shown in Figure 33.



Figure 33: Power saving and paging in GSM networks

The varying pauses explain the different potential for power saving. The longer the pause the less power is consumed.

Generally, power saving depends on the module's application scenario and may differ from the above mentioned normal operation. The power saving interval may be shorter than 0.47 seconds or longer than 2.12 seconds.

## 3.4 Power Supply

BGS5 needs to be connected to a power supply at the SMT application interface (2 lines each BATT+ and GND).

The power supply of BGS5 has to be a single voltage source at BATT+. It must be able to provide the peak current during the uplink transmission.

All the key functions for supplying power to the device are handled by the power management section of the analog controller. This IC provides the following features:

- Stabilizes the supply voltages for the baseband using low drop linear voltage regulators and a DC-DC step down switching regulator.
- Switches the module's power voltages for the power-up and -down procedures.
- SIM switch to provide SIM power supply.

## 3.4 Power Supply

## 3.4.1 Power Supply Ratings

Table 14: Power supply ratings

	Description	Conditions	Min	Typ	Max	Unit		
BATT+	Supply voltage	Directly measured at Module. Voltage must stay within the min/max values, including voltage drop, ripple, spikes	3.3		4.5	V		
	Maximum allowed voltage drop during transmit burst	Normal condition, power control level for Pout max			400	mV		
	Voltage ripple	Normal condition, power control level for Pout max @ f ≤ 250 kHz @ f > 250 kHz			190 30	mV <sub>pp</sub> mV <sub>pp</sub>		
I <sub>VDDL</sub> @ 2.3V	OFF State supply current	RTC backup @ BATT+ = 0V			2.4	μA		
I <sub>BATT+</sub> <sup>1</sup>	OFF State supply current	POWER DOWN	41	41	42	μA		
	Average GSM / GPRS supply current	SLEEP <sup>2</sup> @ DRX=9 (UART deactivated)	USB disconnected		0.75		mA	
		SLEEP <sup>2</sup> @ DRX=5 (UART deactivated)	USB disconnected		0.85		mA	
		SLEEP <sup>2</sup> @ DRX=2 (UART deactivated)	USB disconnected		1.25		mA	
		IDLE @ DRX=2 (UART activated, but no communication)	USB disconnected		21		mA	
		IDLE @ DRX=2 (UART activated, but no communication)	USB suspend		26		mA	
		Voice Call GSM850/900; PCL=5			210		mA	
		GPRS Data transfer GSM850/900; PCL=5; 1Tx/4Rx	ROPR=4 (max. reduction)			188		mA
			ROPR=3			188		
			ROPR=2			190		
			ROPR=1			192		
			ROPR=0 (no reduction)			198		
		GPRS Data transfer GSM850/900; PCL=5; 2Tx/3Rx	ROPR=4 (max. reduction)			265		mA
ROPR=3				263				
ROPR=2				307				
ROPR=1				347				
ROPR=0 (no reduction)				352				

## 3.4 Power Supply

Table 14: Power supply ratings

	Description	Conditions	Min	Typ	Max	Unit		
$I_{BATT+}$ <sup>1</sup>	Average GSM / GPRS supply current	GPRS Data transfer GSM850/900; PCL=5; 4Tx/1Rx	ROPR=4 (max. reduction)		313		mA	
			ROPR=3		313			
			ROPR=2		375			
			ROPR=1		486			
			ROPR=0 (no reduction)		653			
		Voice Call GSM1800/1900; PCL=0			155		mA	
		GPRS Data transfer GSM1800/1900; PCL=0; 1Tx/4Rx		ROPR=4 (max. reduction)		137		mA
				ROPR=3		138		
				ROPR=2		138		
				ROPR=1		139		
				ROPR=0 (no reduction)		146		
		GPRS Data transfer GSM1800/1900; PCL=0; 2Tx/3Rx		ROPR=4 (max. reduction)		210		mA
				ROPR=3		211		
				ROPR=2		230		
				ROPR=1		245		
				ROPR=0 (no reduction)		268		
		GPRS Data transfer GSM1800/1900; PCL=0; 4Tx/1Rx		ROPR=4 (max. reduction)		279		mA
				ROPR=3		278		
				ROPR=2		332		
				ROPR=1		380		
ROPR=0 (no reduction)					472			
Peak current during GSM transmit burst		VOICE Call GSM850/900; PCL=5		1.35	1.64	A		
		VOICE Call GSM1800/1900; PCL=0		1.1	1.2	A		

1. With an impedance of  $Z_{LOAD}=50\Omega$  at the antenna connector.

2. Measurements start 6 minutes after switching ON the module,

Averaging times: SLEEP mode - 3 minutes, transfer modes - 1.5 minutes

Communication tester settings: no neighbour cells, no cell reselection etc., RMC (reference measurement channel)

SLEEP mode (power saving) is enabled by means of the AT command  $AT^SPOW=2,1000,3$

## 3.4 Power Supply

### 3.4.2 Minimizing Power Losses

When designing the power supply for your application please pay specific attention to power losses. Ensure that the input voltage  $V_{\text{BATT+}}$  never drops below 3.3V on the BGS5 board, not even in a GSM transmit burst where current consumption can rise (for peak values see the power supply ratings listed in [Section 3.4.1](#)). Any voltage drops that may occur in a transmit burst should not exceed 400mV.

The module switches off if the minimum battery voltage ( $V_{\text{BattMin}}$ ) is reached.

Example:

$$V_{\text{BattLowLimit}} = 3.3\text{V}$$

$$D_{\text{DropMax}} = 0.4\text{V}$$

$$V_{\text{BattMin}} = V_{\text{BattLowLimit}} + D_{\text{DropMax}}$$

$$V_{\text{BattMin}} = 3.3\text{V} + 0.4\text{V} = 3.7\text{V}$$

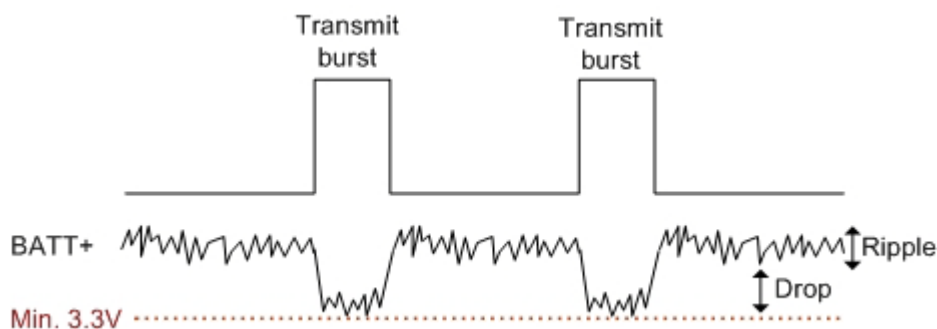

Figure 34: Power supply limits during transmit burst

### 3.4.3 Measuring the Supply Voltage ( $V_{\text{BATT+}}$ )

To measure the supply voltage  $V_{\text{BATT+}}$ , it is possible to define two reference points GND and BATT+. GND should be the module's shielding, while BATT+ should be a test pad on the external application the module is mounted on. The external BATT+ reference point has to be connected to and positioned close to the SMT application interface's BATT+ pads 5 or 53 as shown in [Figure 35](#).

Reference point BATT+:

External test pad connected to and positioned closely to BATT+ pad 5 or 53.

Reference point GND:

Module shielding

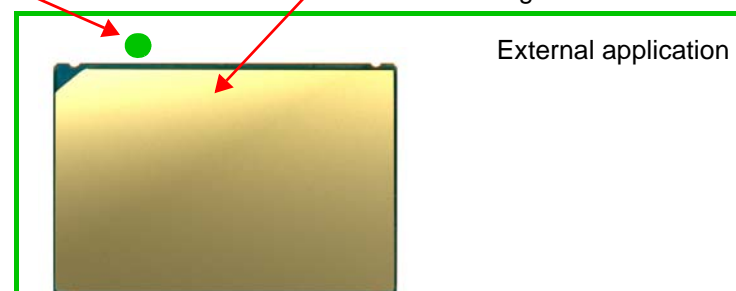

Figure 35: Position of reference points BATT+ and GND

## 3.5 Operating Temperatures

**Table 15:** Board temperature

Parameter	Min	Typ	Max	Unit
Operating temperature range <sup>1</sup>				
Normal temperature range	+15	+25	+55	°C
Extreme temperature range	-30		+85	°C
Extended temperature range <sup>2</sup>	-40		+90	°C
Automatic shutdown <sup>3</sup>				
Temperature measured on BGS5 board	<-40	---	>+90	°C

1. Operating temperature range according to 3GPP type approval specification.

2. Extended operation allows normal mode data transmissions for limited time until automatic thermal shutdown takes effect.

Within the extended temperature range (outside the operating temperature range) there will be no inefficient use of the radio spectrum and no harm to the radio network. Also, there should not be any unrecoverable malfunctioning. General performance parameters like Pout or RX sensitivity however may be reduced in their values. The module's life time may also be affected, if deviating from a general temperature allocation model (for details see [Section 3.5.1](#)).

3. Due to temperature measurement uncertainty, a tolerance on the stated shutdown thresholds may occur. The possible deviation is in the range of  $\pm 2^\circ\text{C}$  at the overtemperature and undertemperature limit.

See also [Section 3.2.5](#) for information about the NTC for on-board temperature measurement, automatic thermal shutdown and alert messages.

Note that within the specified operating temperature ranges the board temperature may vary to a great extent depending on operating mode, used frequency band, radio output power and current supply voltage.

### 3.5.1 Temperature Allocation Model

The temperature allocation model shown in [Table 16](#) assumes shares of a module's average lifetime of 10 years (given in %) during which the module is operated at certain temperatures.

**Table 16:** Temperature allocation model

Module lifetime share (in %) <sup>1</sup>	1	1	5	53	35	3	1	1
Module temperature (in °C)	-40	-30	-10	20	40	70	85	90

1. Based on an assumed average module lifetime of 10 years (=100%).

Any deviations from the above temperature allocation model may reduce the module's life span, for example if the module is operated close to the maximum automatic shutdown temperature not only for 1% but for 20% of its product life.

## 3.6 Electrostatic Discharge

The GSM module is not protected against Electrostatic Discharge (ESD) in general. Consequently, it is subject to ESD handling precautions that typically apply to ESD sensitive components. Proper ESD handling and packaging procedures must be applied throughout the processing, handling and operation of any application that incorporates a BGS5 module.

An example for an enhanced ESD protection for the SIM interface is given in [Section 2.1.6.1](#).

BGS5 has been tested according to group standard ETSI EN 301 489-1 (see [Table 24](#)) and test standard EN 61000-4-2. Electrostatic values can be gathered from the following table.

**Table 17:** Electrostatic values

Specification/Requirements	Contact discharge	Air discharge
<b>EN 61000-4-2</b>		
Antenna interface	$\pm 1\text{kV}$	n.a.
Antenna interface with ESD protection (see <a href="#">Section 3.6.1</a> )	$\pm 4\text{kV}$	$\pm 8\text{kV}$
<b>JEDEC JESD22-A114D</b> (Human Body Model, Test conditions: 1.5 k $\Omega$ , 100 pF)		
All other interfaces	$\pm 1\text{kV}$	n.a.

*Note: Please note that the values may vary with the individual application design. For example, it matters whether or not the application platform is grounded over external devices like a computer or other equipment, such as the Gemalto M2M reference application described in [Chapter 5](#).*

### 3.6.1 ESD Protection for Antenna Interface

The following [Figure 36](#) shows how to implement an external ESD protection for the RF antenna interface with either a T pad or PI pad attenuator circuit (for RF line routing design see also [Section 2.2.3](#)).

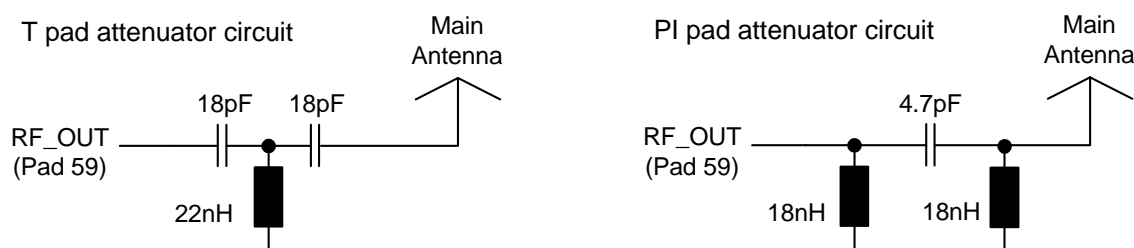

**Figure 36:** ESD protection for RF antenna interface

Recommended inductor types for the above sample circuits: Size 0402 SMD from Panasonic ELJRF series (22nH and 18nH inductors) or Murata LQW15AN18NJ00 (18nH inductors only).

### 3.6.2 Blocking against RF on Interface Lines

To reduce EMI issues there are serial resistors, or capacitors to GND, implemented on the module for the ignition, emergency restart, and SIM interface lines (cp. [Section 2.3](#)). However, all other signal lines have no EMI measures on the module and there are no blocking measures at the module's interface to an external application.

Dependent on the specific application design, it might be useful to implement further EMI measures on some signal lines at the interface between module and application. These measures are described below.

There are five possible variants of EMI measures (A-E) that may be implemented between module and external application depending on the signal line (see [Figure 37](#) and [Table 18](#)). Pay attention not to exceed the maximum input voltages and prevent voltage overshots if using inductive EMC measures.

The maximum value of the serial resistor should be lower than 1kOhm on the signal line. The maximum value of the capacitor should be lower than 50pF on the signal line. Please observe the electrical specification of the module's SMT application interface and the external application's interface.

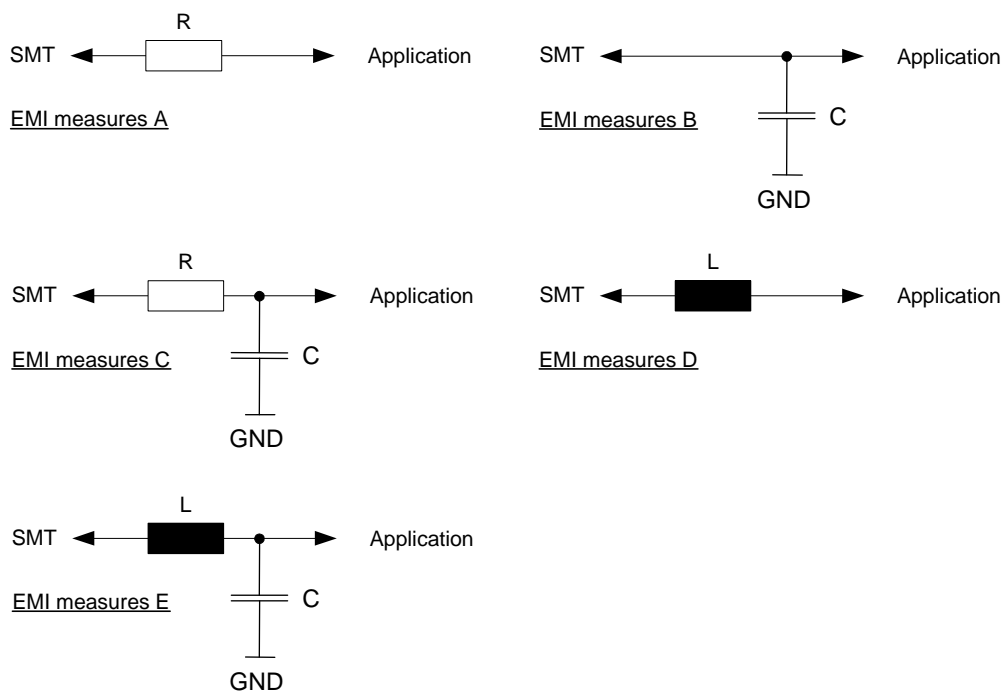

**Figure 37:** EMI circuits



## 3.6 Electrostatic Discharge

The following table lists for each signal line at the module's SMT application interface the EMI measures that may be implemented.

**Table 18:** EMI measures on the application interface

Signal name	EMI measures					Remark
	A	B	C	D	E	
CCIN	x			x		
CCRST		x				The external capacitor should be not higher than 30pF. The value of the capacitor depends on the external application.
CCIO		x				
CCCLK		x				
RXD0	x	x	x	x	x	
TXD0	x	x	x	x	x	
CTS0	x	x	x	x	x	
RTS0				x		
DTR0/GPIO1	x	x	x	x	x	
DCD0/GPIO2	x	x	x	x	x	
DSR0/GPIO3	x	x	x	x	x	
GPIO4/FST_SHDN	x	x	x	x	x	
GPIO5/LED	x	x	x	x	x	
GPIO6/PWM2	x	x	x	x	x	
GPIO7/PWM1	x	x	x	x	x	
GPIO8/COUNTER	x	x	x	x	x	
RXD1/GPIO16/MOSI	x	x	x	x	x	
TXD1/GPIO17/MISO	x	x	x	x	x	
RTS1/GPIO18/SPI_CLK	x	x	x	x	x	
CTS1/GPIO19/SPI_CS	x	x	x	x	x	
GPIO20/TXDDAI	x	x	x	x	x	
GPIO21/RXDDAI	x	x	x	x	x	
GPIO22/TFSDAI	x	x	x	x	x	
GPIO23/SCLK	x	x	x	x	x	
GPIO24/RING0	x	x	x	x	x	
I2CDAT		x		x		The rising signal edge is reduced with an additional capacitor.
I2CCLK		x		x		
V180		x		x	x	
VCORE		x		x	x	

### 3.7 Reliability Characteristics

The test conditions stated below are an extract of the complete test specifications.

**Table 19:** Summary of reliability test conditions

Type of test	Conditions	Standard
Vibration	Frequency range: 10-20Hz; acceleration: 5g Frequency range: 20-500Hz; acceleration: 20g Duration: 20h per axis; 3 axes	DIN IEC 60068-2-6 <sup>1</sup>
Shock half-sinus	Acceleration: 500g Shock duration: 1msec 1 shock per axis 6 positions ( $\pm$ x, y and z)	DIN IEC 60068-2-27
Dry heat	Temperature: +70 $\pm$ 2°C Test duration: 16h Humidity in the test chamber: < 50%	EN 60068-2-2 Bb ETS 300 019-2-7
Temperature change (shock)	Low temperature: -40°C $\pm$ 2°C High temperature: +85°C $\pm$ 2°C Changeover time: < 30s (dual chamber system) Test duration: 1h Number of repetitions: 100	DIN IEC 60068-2-14 Na ETS 300 019-2-7
Damp heat cyclic	High temperature: +55°C $\pm$ 2°C Low temperature: +25°C $\pm$ 2°C Humidity: 93% $\pm$ 3% Number of repetitions: 6 Test duration: 12h + 12h	DIN IEC 60068-2-30 Db ETS 300 019-2-5
Cold (constant exposure)	Temperature: -40 $\pm$ 2°C Test duration: 16h	DIN IEC 60068-2-1

1. For reliability tests in the frequency range 20-500Hz the Standard's acceleration reference value was increased to 20g.

## 4 Mechanical Dimensions, Mounting and Packaging

The following sections describe the mechanical dimensions of BGS5 and give recommendations for integrating BGS5 into the host application.

### 4.1 Mechanical Dimensions of BGS5

Figure 38 shows the top and bottom view of BGS5 and provides an overview of the board's mechanical dimensions. For further details see Figure 39.

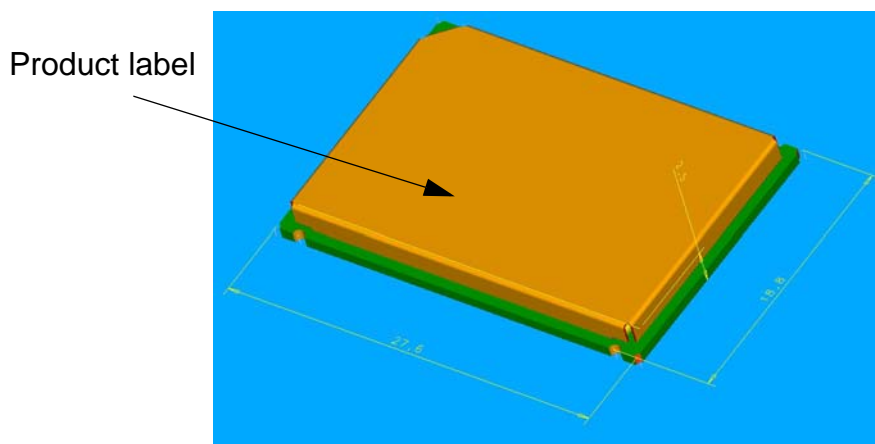

Top view

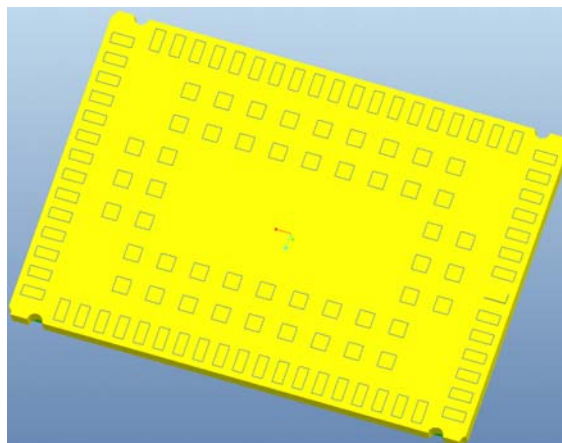

Bottom view

**Figure 38:** BGS5– top and bottom view

4.1 Mechanical Dimensions of BGS5

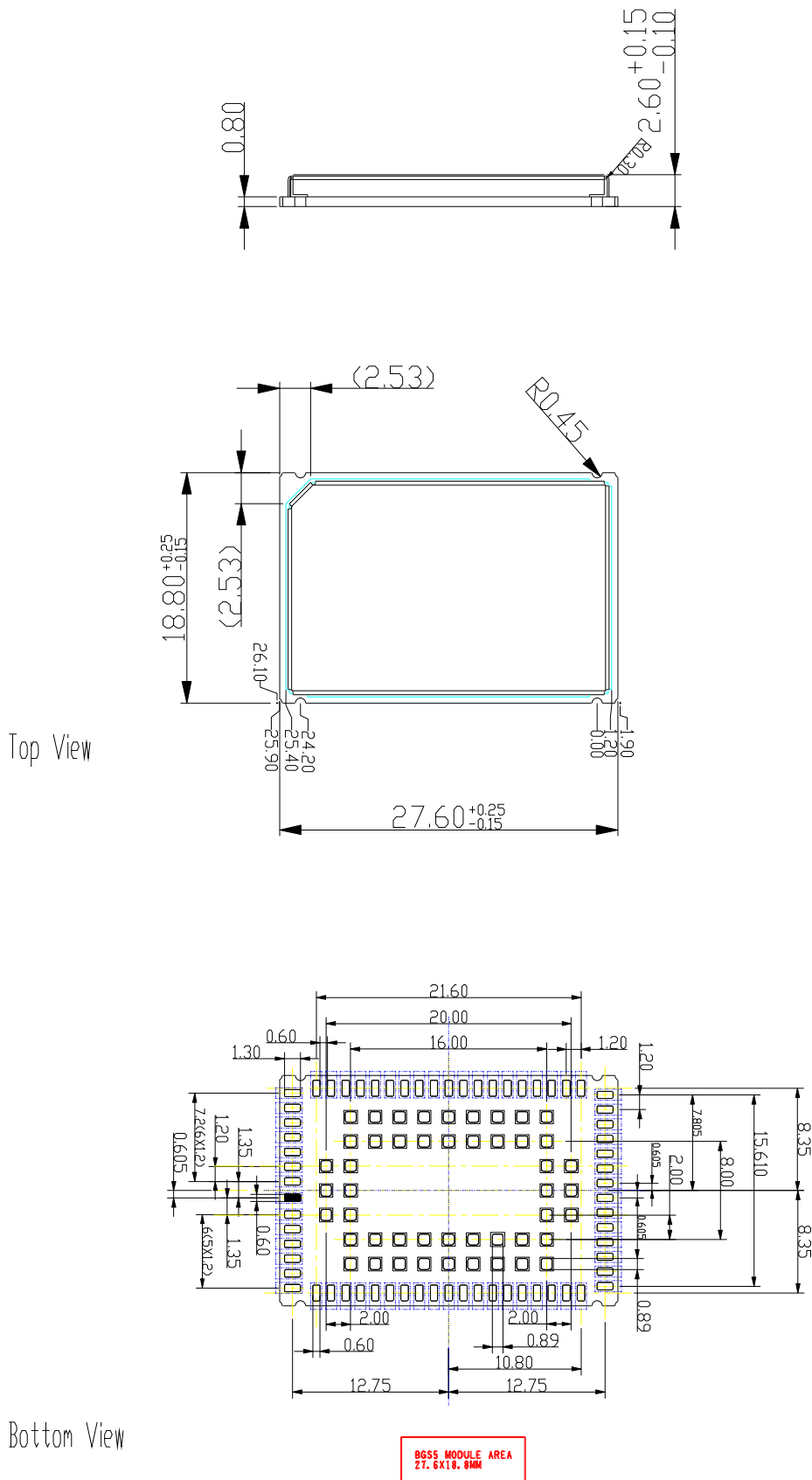

Figure 39: Dimensions of BGS5 (all dimensions in mm)

## 4.2 Mounting BGS5 onto the Application Platform

This section describes how to mount BGS5 onto the PCBs (=printed circuit boards), including land pattern and stencil design, board-level characterization, soldering conditions, durability and mechanical handling. For more information on issues related to SMT module integration see also [3].

**Note:** To avoid short circuits between signal tracks on an external application's PCB and various markings at the bottom side of the module, it is recommended not to route the signal tracks on the top layer of an external PCB directly under the module, or at least to ensure that signal track routes are sufficiently covered with solder resist.

### 4.2.1 SMT PCB Assembly

#### 4.2.1.1 Land Pattern and Stencil

The land pattern and stencil design as shown below is based on Gemalto M2M characterizations for lead-free solder paste on a four-layer test PCB and a 120 respectively 150 micron thick stencil.

The land pattern given in [Figure 40](#) reflects the module's pad layout, including signal pads and ground pads (for pad assignment see [Section 2.1.1](#)).

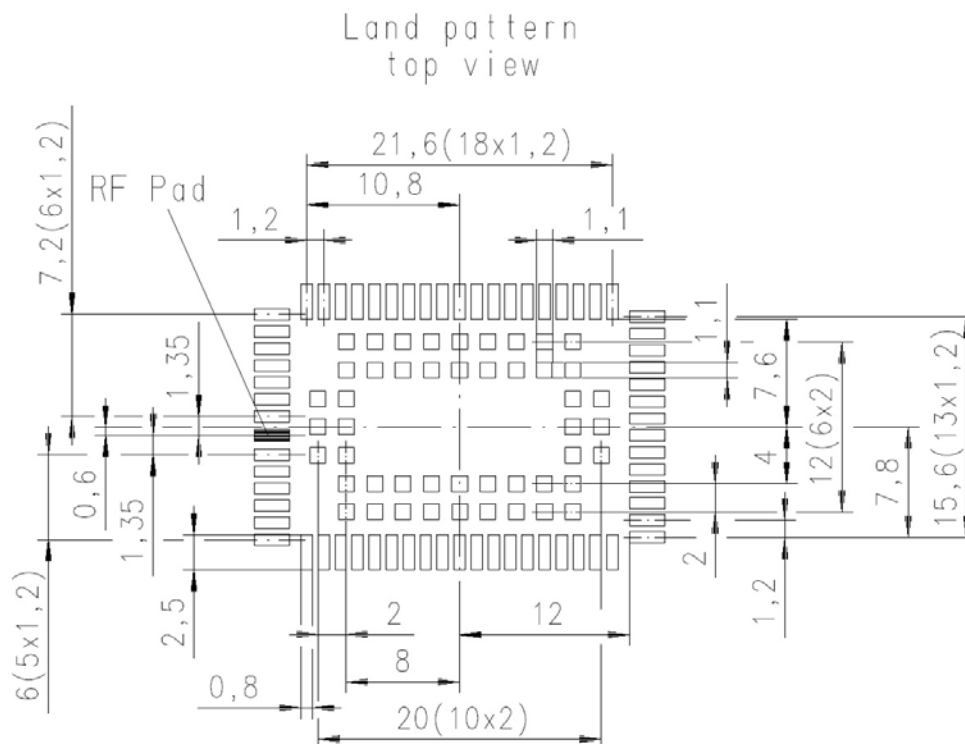

**Figure 40:** Land pattern (top view)

The stencil design illustrated in [Figure 41](#) and [Figure 42](#) is recommended by Gemalto M2M as a result of extensive tests with Gemalto M2M Daisy Chain modules.

The central ground pads are primarily intended for stabilizing purposes, and may show some more voids than the application interface pads at the module's rim. This is acceptable, since they are electrically irrelevant.

4.2 Mounting BGS5 onto the Application Platform

Note that depending on coplanarity or other properties of the external PCB, it could be that all of the central ground pads may have to be soldered. For this reason the land pattern design shown in [Figure 40](#) provides for both of these alternatives and only a modification of the stencil may be needed.

Stencil 120um  
Top View

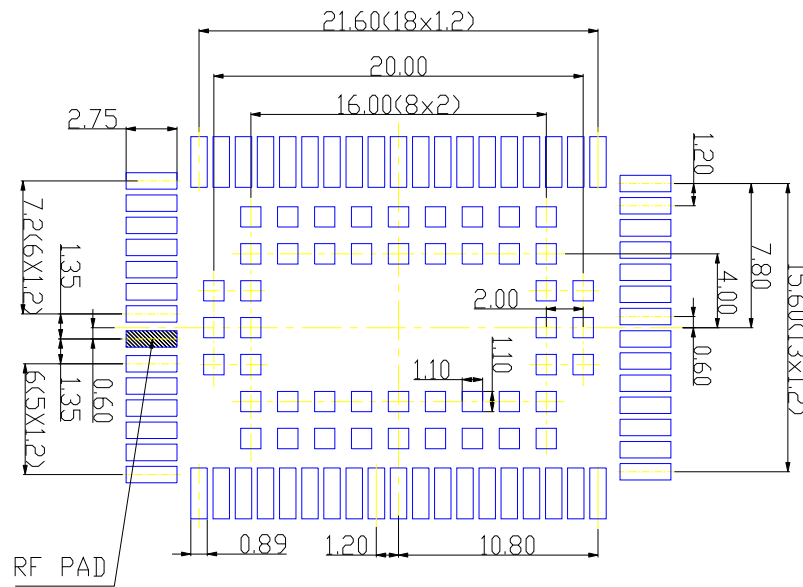

Figure 41: Recommended design for 120 micron thick stencil (top view)

Stencil 150um  
Top View

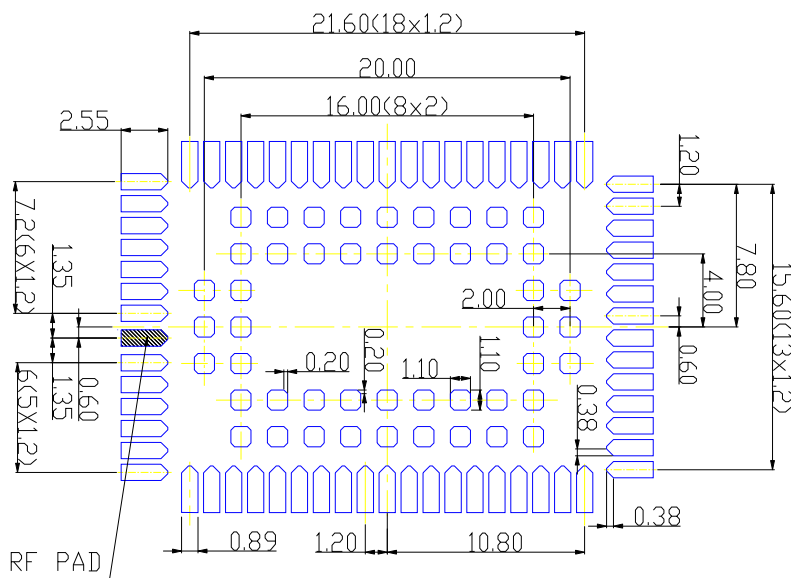

Figure 42: Recommended design for 150 micron thick stencil (top view)

### 4.2.1.2 Board Level Characterization

Board level characterization issues should also be taken into account if devising an SMT process.

Characterization tests should attempt to optimize the SMT process with regard to board level reliability. This can be done by performing the following physical tests on sample boards: Peel test, bend test, tensile pull test, drop shock test and temperature cycling. Sample surface mount checks are described in [\[3\]](#).

It is recommended to characterize land patterns before an actual PCB production, taking individual processes, materials, equipment, stencil design, and reflow profile into account. For land and stencil pattern design recommendations see also [Section 4.2.1.1](#). Optimizing the solder stencil pattern design and print process is necessary to ensure print uniformity, to decrease solder voids, and to increase board level reliability.

Daisy chain modules for SMT characterization are available on request. For details refer to [\[3\]](#).

Generally, solder paste manufacturer recommendations for screen printing process parameters and reflow profile conditions should be followed. Maximum ratings are described in [Section 4.2.3](#).

## 4.2.2 Moisture Sensitivity Level

BGS5 comprises components that are susceptible to damage induced by absorbed moisture.

Gemalto M2M's BGS5 module complies with the latest revision of the IPC/JEDEC J-STD-020 Standard for moisture sensitive surface mount devices and is classified as MSL 4.

For additional MSL (=moisture sensitivity level) related information see [Section 4.2.4](#) and [Section 4.3.2](#).

## 4.2.3 Soldering Conditions and Temperature

### 4.2.3.1 Reflow Profile

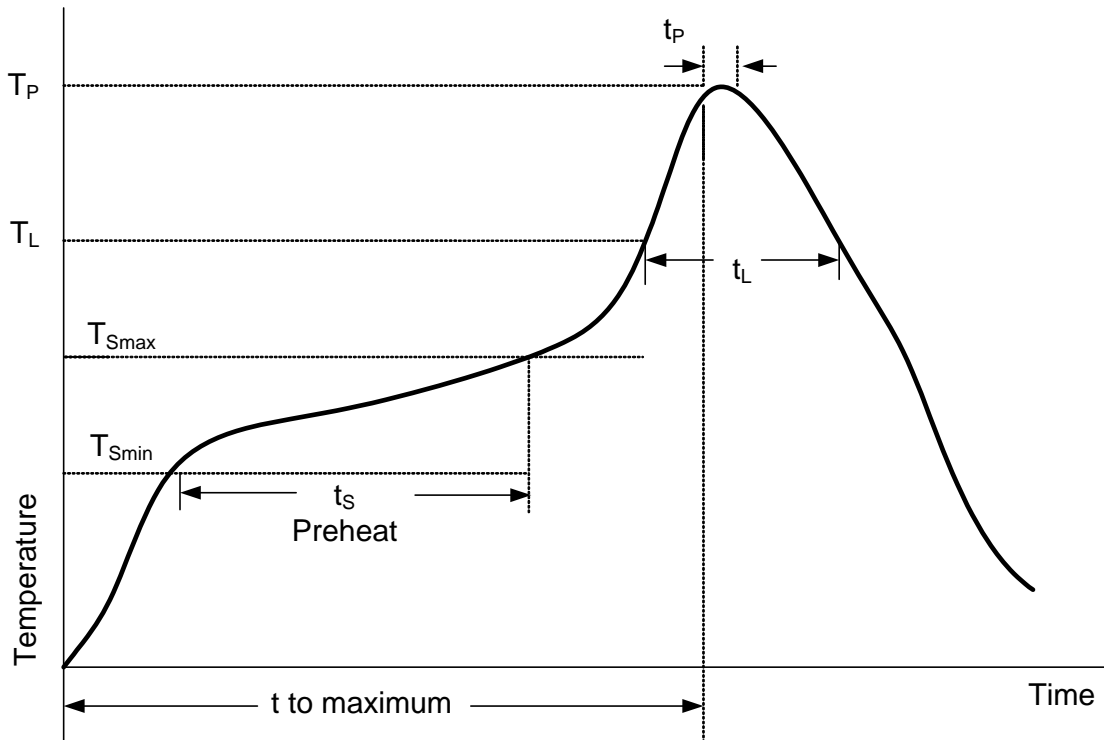

Figure 43: Reflow Profile

Table 20: Reflow temperature ratings

Profile Feature	Pb-Free Assembly
Preheat & Soak Temperature Minimum ( $T_{Smin}$ ) Temperature Maximum ( $T_{Smax}$ ) Time ( $t_{Smin}$ to $t_{Smax}$ ) ( $t_S$ )	150°C 200°C 60-120 seconds
Average ramp up rate ( $T_{Smax}$ to $T_P$ )	3K/second max.
Liquidous temperature ( $T_L$ ) Time at liquidous ( $t_L$ )	217°C 60-90 seconds
Peak package body temperature ( $T_P$ )	245°C +0/-5°C
Time ( $t_P$ ) within 5 °C of the peak package body temperature ( $T_P$ )	30 seconds max.
Average ramp-down rate ( $T_P$ to $T_{Smax}$ )	6 K/second max.
Time 25°C to maximum temperature	8 minutes max.



### 4.2.3.2 Maximum Temperature and Duration

The following limits are recommended for the SMT board-level soldering process to attach the module:

- A maximum module temperature of 245°C. This specifies the temperature as measured at the module's top side.
- A maximum duration of 30 seconds at this temperature.

Please note that while the solder paste manufacturers' recommendations for best temperature and duration for solder reflow should generally be followed, the limits listed above must not be exceeded.

BGS5 is specified for one soldering cycle only. Once BGS5 is removed from the application, the module will very likely be destroyed and cannot be soldered onto another application.

## 4.2.4 Durability and Mechanical Handling

### 4.2.4.1 Storage Conditions

BGS5 modules, as delivered in tape and reel carriers, must be stored in sealed, moisture barrier anti-static bags. The conditions stated below are only valid for modules in their original packed state in weather protected, non-temperature-controlled storage locations. Normal storage time under these conditions is 12 months maximum.

**Table 21:** Storage conditions

Type	Condition	Unit	Reference
Air temperature: Low High	-25 +40	°C	IPC/JEDEC J-STD-033A
Humidity relative: Low High	10 90 at 40°C	%	IPC/JEDEC J-STD-033A
Air pressure: Low High	70 106	kPa	IEC TR 60271-3-1: 1K4 IEC TR 60271-3-1: 1K4
Movement of surrounding air	1.0	m/s	IEC TR 60271-3-1: 1K4
Water: rain, dripping, icing and frosting	Not allowed	---	---
Radiation: Solar Heat	1120 600	W/m <sup>2</sup>	ETS 300 019-2-1: T1.2, IEC 60068-2-2 Bb ETS 300 019-2-1: T1.2, IEC 60068-2-2 Bb
Chemically active substances	Not recommended		IEC TR 60271-3-1: 1C1L
Mechanically active substances	Not recommended		IEC TR 60271-3-1: 1S1
Vibration sinusoidal: Displacement Acceleration Frequency range	1.5 5 2-9 9-200	mm m/s <sup>2</sup> Hz	IEC TR 60271-3-1: 1M2
Shocks: Shock spectrum Duration Acceleration	semi-sinusoidal 1 50	ms m/s <sup>2</sup>	IEC 60068-2-27 Ea

#### 4.2.4.2 Processing Life

BGS5 must be soldered to an application within 72 hours after opening the MBB (=moisture barrier bag) it was stored in.

As specified in the IPC/JEDEC J-STD-033 Standard, the manufacturing site processing the modules should have ambient temperatures below 30°C and a relative humidity below 60%.

#### 4.2.4.3 Baking

Baking conditions are specified on the moisture sensitivity label attached to each MBB (see [Figure 48](#) for details):

- It is *not necessary* to bake BGS5, if the conditions specified in [Section 4.2.4.1](#) and [Section 4.2.4.2](#) were not exceeded.
- It is *necessary* to bake BGS5, if any condition specified in [Section 4.2.4.1](#) and [Section 4.2.4.2](#) was exceeded.

If baking is necessary, the modules must be put into trays that can be baked to at least 125°C. Devices should not be baked in tape and reel carriers at any temperature.

#### 4.2.4.4 Electrostatic Discharge

ESD (=electrostatic discharge) may lead to irreversible damage for the module. It is therefore advisable to develop measures and methods to counter ESD and to use these to control the electrostatic environment at manufacturing sites.

Please refer to [Section 3.6](#) for further information on electrostatic discharge.

4.3 Packaging

4.3 Packaging

4.3.1 Tape and Reel

The single-feed tape carrier for BGS5 is illustrated in Figure 44. The figure also shows the proper part orientation. The tape width is 44 mm and the BGS5 modules are placed on the tape with a 28-mm pitch. The reels are 330 mm in diameter with a core diameter of 100 mm. Each reel contains 500 modules.

4.3.1.1 Orientation

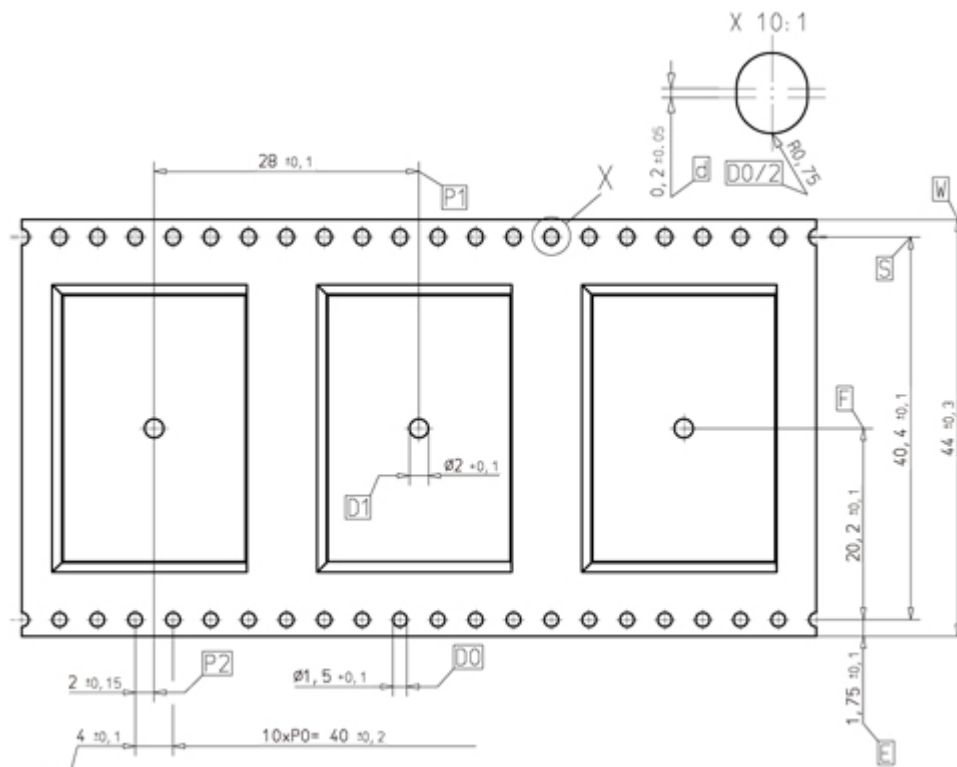

Figure 44: Carrier tape

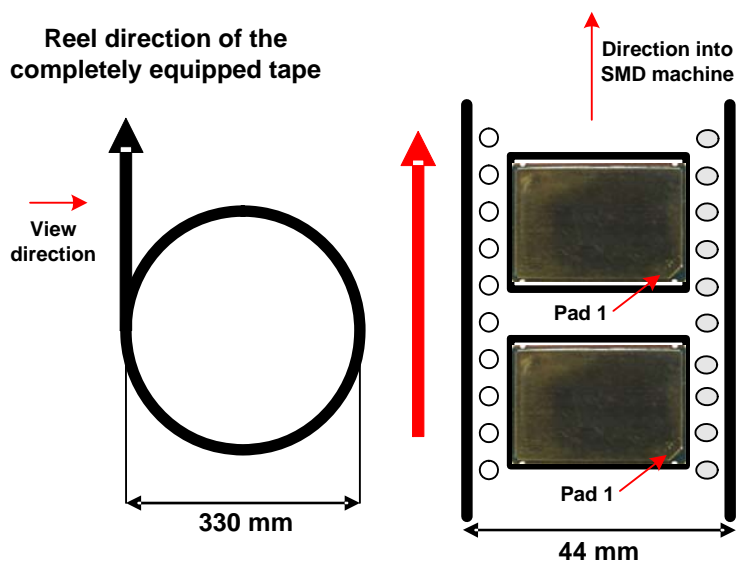
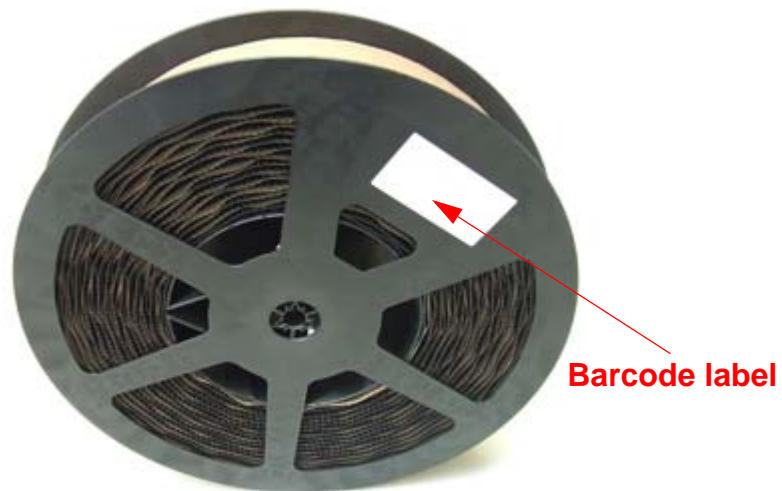

Figure 45: Reel direction

### 4.3.1.2 Barcode Label

A barcode label provides detailed information on the tape and its contents. It is attached to the reel.



**Figure 46:** Barcode label on tape reel

## 4.3.2 Shipping Materials

BGS5 is distributed in tape and reel carriers. The tape and reel carriers used to distribute BGS5 are packed as described below, including the following required shipping materials:

- Moisture barrier bag, including desiccant and humidity indicator card
- Transportation box

### 4.3.2.1 Moisture Barrier Bag

The tape reels are stored inside an MBB (=moisture barrier bag), together with a humidity indicator card and desiccant pouches - see [Figure 47](#). The bag is ESD protected and delimits moisture transmission. It is vacuum-sealed and should be handled carefully to avoid puncturing or tearing. The bag protects the BGS5 modules from moisture exposure. It should not be opened until the devices are ready to be soldered onto the application.

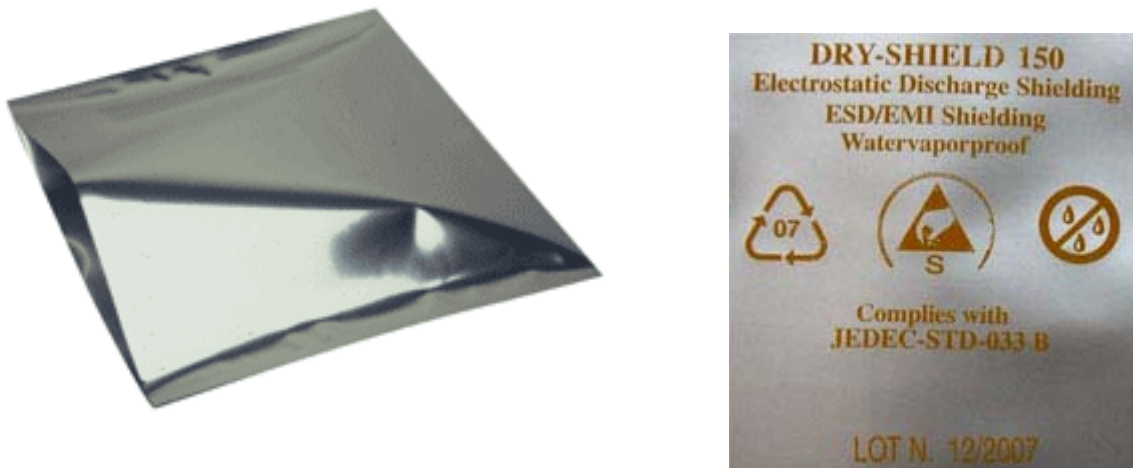

**Figure 47:** Moisture barrier bag (MBB) with imprint

The label shown in [Figure 48](#) summarizes requirements regarding moisture sensitivity, including shelf life and baking requirements. It is attached to the outside of the moisture barrier bag.



**CAUTION**

This bag contains

**MOISTURE-SENSITIVE DEVICES**

LEVEL

4

1. Calculated shelf life in sealed bag:  
12 months at < 40 °C and < 90% relative humidity (RH)
2. Peak package body temperature: 245 °C
3. After bag is opened, devices that will be subject to reflow solder or other high temperature process must be
  - a) mounted within: 72 hours of factory conditions < 30 °C / 60% RH
  - b) stored at < 10% RH
4. Devices require bake, before mounting, if
  - a) Humidity Indicator Card is > 10% when read at 23 +/- 5 °C
  - b) 3a or 3b not met
5. If baking is required, refer to IPC/Jedec J-STD-033 for bake procedure

Note: The devices are shipped in a non heat-resistant carrier and may not be baked in the carriers

Bag Seal Date: DD.MM.YYYY

Note: MSL level and body temperature defined by IPC/JEDEC J-STD-020

# CINTERION

INFO-2
DELIVERYPARTNUMBER

Peak package body temperature: 245°C

Qty.: 000

Bag Seal Date (DDMMYYYY) : DDMMYY YY



Package ID: WM8000123412



Figure 48: Moisture Sensitivity Label

## 4.3 Packaging

MBBs contain one or more desiccant pouches to absorb moisture that may be in the bag. The humidity indicator card described below should be used to determine whether the enclosed components have absorbed an excessive amount of moisture.

The desiccant pouches should not be baked or reused once removed from the MBB.

The humidity indicator card is a moisture indicator and is included in the MBB to show the approximate relative humidity level within the bag. Sample humidity cards are shown in [Figure 49](#). If the components have been exposed to moisture above the recommended limits, the units will have to be rebaked.

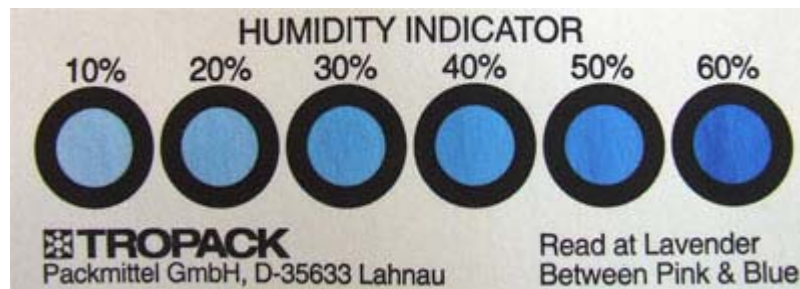

Figure 49: Humidity Indicator Card - HIC

A baking is required if the humidity indicator inside the bag indicates 10% RH or more.

#### 4.3.2.2 Transportation Box

Tape and reel carriers are distributed in a box, marked with a barcode label for identification purposes. A box contains two reels with 500 modules each.



### 4.3.3 Trays

If small module quantities are required, e.g., for test and evaluation purposes, BGS5 may be distributed in trays (for dimensions see [Figure 53](#)). The small quantity trays are an alternative to the single-feed tape carriers normally used. However, the trays are not designed for machine processing. They contain modules to be (hand) soldered onto an external application (for information on hand soldering see [\[3\]](#)).

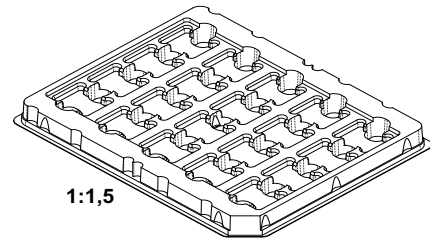

Figure 50: Small quantity tray

Trays are packed and shipped in the same way as tape carriers, including a moisture barrier bag with desiccant and humidity indicator card as well as a transportation box (see also [Section 4.3.2](#)).



Figure 51: Tray to ship odd module amounts



Figure 52: Trays with packaging materials

4.3 Packaging

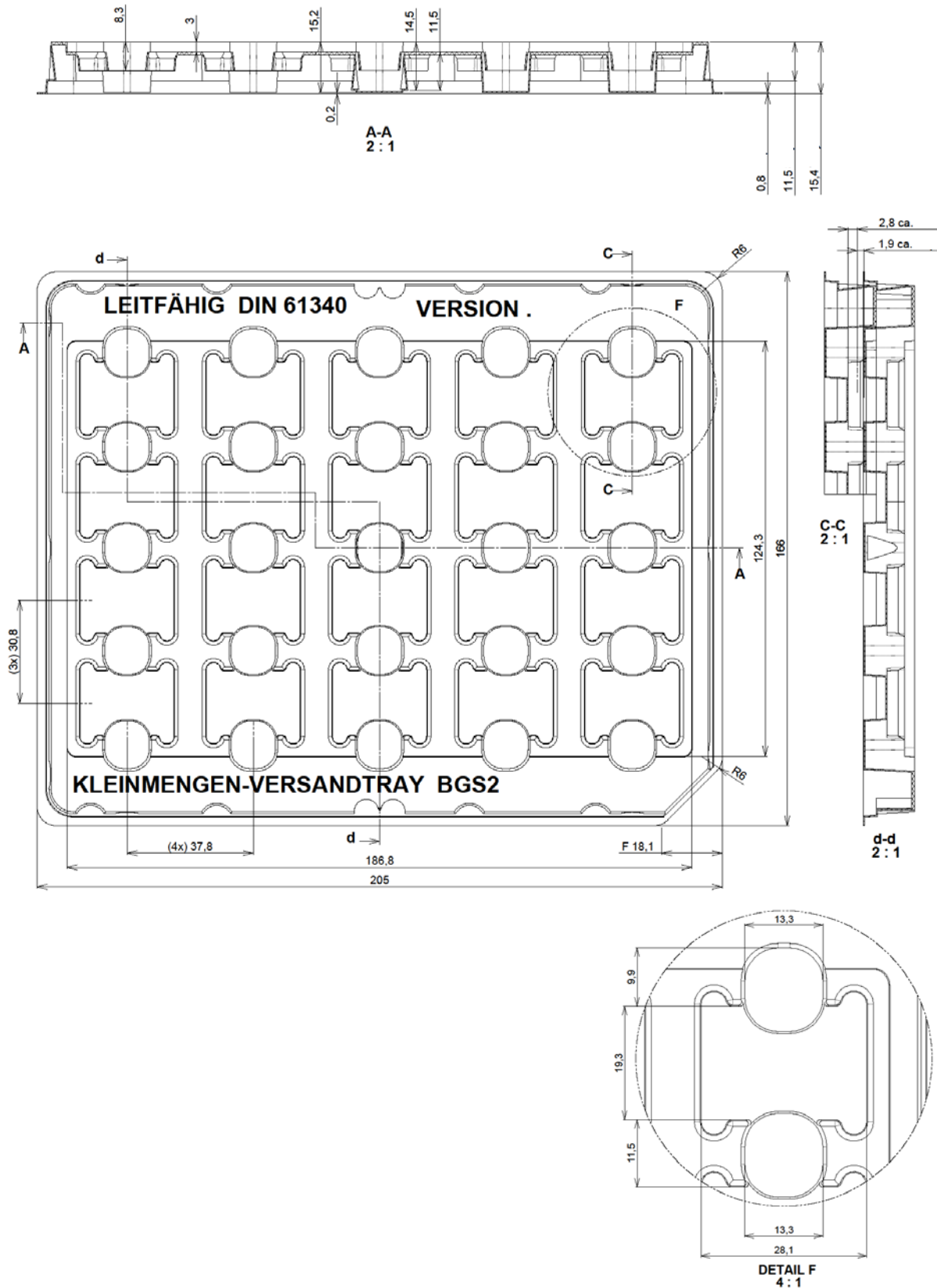

Figure 53: Tray dimensions

## 5 Regulatory and Type Approval Information

### 5.1 Directives and Standards

BGS5 is designed to comply with the directives and standards listed below.

It is the responsibility of the application manufacturer to ensure compliance of the final product with all provisions of the applicable directives and standards as well as with the technical specifications provided in the "BGS5 Hardware Interface Description".<sup>1</sup>

**Table 22:** Directives

1999/05/EC	Directive of the European Parliament and of the council of 9 March 1999 on radio equipment and telecommunications terminal equipment and the mutual recognition of their conformity (in short referred to as R&TTE Directive 1999/5/EC). The product is labeled with the CE conformity mark <b>CE 0682</b>
2002/95/EC	Directive of the European Parliament and of the Council of 27 January 2003 on the restriction of the use of certain hazardous substances in electrical and electronic equipment (RoHS) 

**Table 23:** Standards of North American type approval<sup>1</sup>

CFR Title 47	Code of Federal Regulations, Part 22 and Part 24 (Telecommunications, PCS); US Equipment Authorization FCC
OET Bulletin 65 (Edition 97-01)	Evaluating Compliance with FCC Guidelines for Human Exposure to Radiofrequency Electromagnetic Fields
UL 60 950-1	Product Safety Certification (Safety requirements) 
NAPRD.03 V5.13	Overview of PCS Type certification review board Mobile Equipment Type Certification and IMEI control PCS Type Certification Review board (PTCRB)
RSS132 (Issue2) RSS133 (Issue5)	Canadian Standard

1. Applies to the module variant BGS5 only.

1. Manufacturers of applications which can be used in the US shall ensure that their applications have a PTCRB approval. For this purpose they can refer to the PTCRB approval of the respective module.

## 5.1 Directives and Standards

**Table 24:** Standards of European type approval<sup>1</sup>

3GPP TS 51.010-1	Digital cellular telecommunications system (Release 7); Mobile Station (MS) conformance specification;
ETSI EN 301 511 V9.0.2	Global System for Mobile communications (GSM); Harmonized standard for mobile stations in the GSM 900 and DCS 1800 bands covering essential requirements under article 3.2 of the R&TTE directive (1999/5/EC)
GCF-CC V3.47	Global Certification Forum - Certification Criteria
ETSI EN 301 489-01 V1.8.1	Electromagnetic Compatibility and Radio spectrum Matters (ERM); Electromagnetic Compatibility (EMC) standard for radio equipment and services; Part 1: Common Technical Requirements
ETSI EN 301 489-07 V1.3.1	Electromagnetic Compatibility and Radio spectrum Matters (ERM); Electromagnetic Compatibility (EMC) standard for radio equipment and services; Part 7: Specific conditions for mobile and portable radio and ancillary equipment of digital cellular radio telecommunications systems (GSM and DCS)
EN 60950-1:2006+ A11:2009+A1:2010 IEC 60950-1:2005/ A1:2009 (second edition)	Safety of information technology equipment

1. Applies to the module variant BGS5 only.

**Table 25:** Requirements of quality

IEC 60068	Environmental testing
DIN EN 60529	IP codes

5.1 Directives and Standards

**Table 26:** Standards of the Ministry of Information Industry of the People’s Republic of China

SJ/T 11363-2006	“Requirements for Concentration Limits for Certain Hazardous Substances in Electronic Information Products” (2006-06).
SJ/T 11364-2006	<p>“Marking for Control of Pollution Caused by Electronic Information Products” (2006-06).</p> <p>According to the “Chinese Administration on the Control of Pollution caused by Electronic Information Products” (ACPEIP) the EPUP, i.e., Environmental Protection Use Period, of this product is 20 years as per the symbol shown here, unless otherwise marked. The EPUP is valid only as long as the product is operated within the operating limits described in the Gemalto M2M Hardware Interface Description.</p> <p>Please see <a href="#">Table 27</a> for an overview of toxic or hazardous substances or elements that might be contained in product parts in concentrations above the limits defined by SJ/T 11363-2006.</p> 

**Table 27:** Toxic or hazardous substances or elements with defined concentration limits

部件名称 Name of the part	有毒有害物质或元素 Hazardous substances					
	铅 (Pb)	汞 (Hg)	镉 (Cd)	六价铬 (Cr(VI))	多溴联苯 (PBB)	多溴二苯醚 (PBDE)
金属部件 (Metal Parts)	○	○	○	○	○	○
电路模块 (Circuit Modules)	X	○	○	○	○	○
电缆及电缆组件 (Cables and Cable Assemblies)	○	○	○	○	○	○
塑料和聚合物部件 (Plastic and Polymeric parts)	○	○	○	○	○	○
<p>O: 表示该有毒有害物质在该部件所有均质材料中的含量均在SJ/T11363-2006 标准规定的限量要求以下。 Indicates that this toxic or hazardous substance contained in all of the homogeneous materials for this part is below the limit requirement in SJ/T11363-2006.</p> <p>X: 表示该有毒有害物质至少在该部件的某一均质材料中的含量超出SJ/T11363-2006标准规定的限量要求。 Indicates that this toxic or hazardous substance contained in at least one of the homogeneous materials used for this part <i>might exceed</i> the limit requirement in SJ/T11363-2006.</p>						

## 5.2 SAR requirements specific to portable mobiles

Mobile phones, PDAs or other portable transmitters and receivers incorporating a GSM module must be in accordance with the guidelines for human exposure to radio frequency energy. This requires the Specific Absorption Rate (SAR) of portable BGS5 based applications to be evaluated and approved for compliance with national and/or international regulations.

Since the SAR value varies significantly with the individual product design manufacturers are advised to submit their product for approval if designed for portable use. For European and US markets the relevant directives are mentioned below. It is the responsibility of the manufacturer of the final product to verify whether or not further standards, recommendations or directives are in force outside these areas.

### *Products intended for sale on US markets*

ES 59005/ANSI C95.1 Considerations for evaluation of human exposure to Electromagnetic Fields (EMFs) from Mobile Telecommunication Equipment (MTE) in the frequency range 30MHz - 6GHz

### *Products intended for sale on European markets*

EN 50360 Product standard to demonstrate the compliance of mobile phones with the basic restrictions related to human exposure to electromagnetic fields (300MHz - 3GHz)

Please note that SAR requirements are specific only for portable devices and not for mobile devices as defined below:

- **Portable device:**  
A portable device is defined as a transmitting device designed to be used so that the radiating structure(s) of the device is/are within 20 centimeters of the body of the user.
- **Mobile device:**  
A mobile device is defined as a transmitting device designed to be used in other than fixed locations and to generally be used in such a way that a separation distance of at least 20 centimeters is normally maintained between the transmitter's radiating structure(s) and the body of the user or nearby persons. In this context, the term "fixed location" means that the device is physically secured at one location and is not able to be easily moved to another location.

## 5.3 Reference Equipment for Type Approval

## 5.3 Reference Equipment for Type Approval

The Gemalto M2M reference setup submitted to type approve BGS5 (including a special approval adapter for the DSB75) is shown in the following figure<sup>1</sup>:

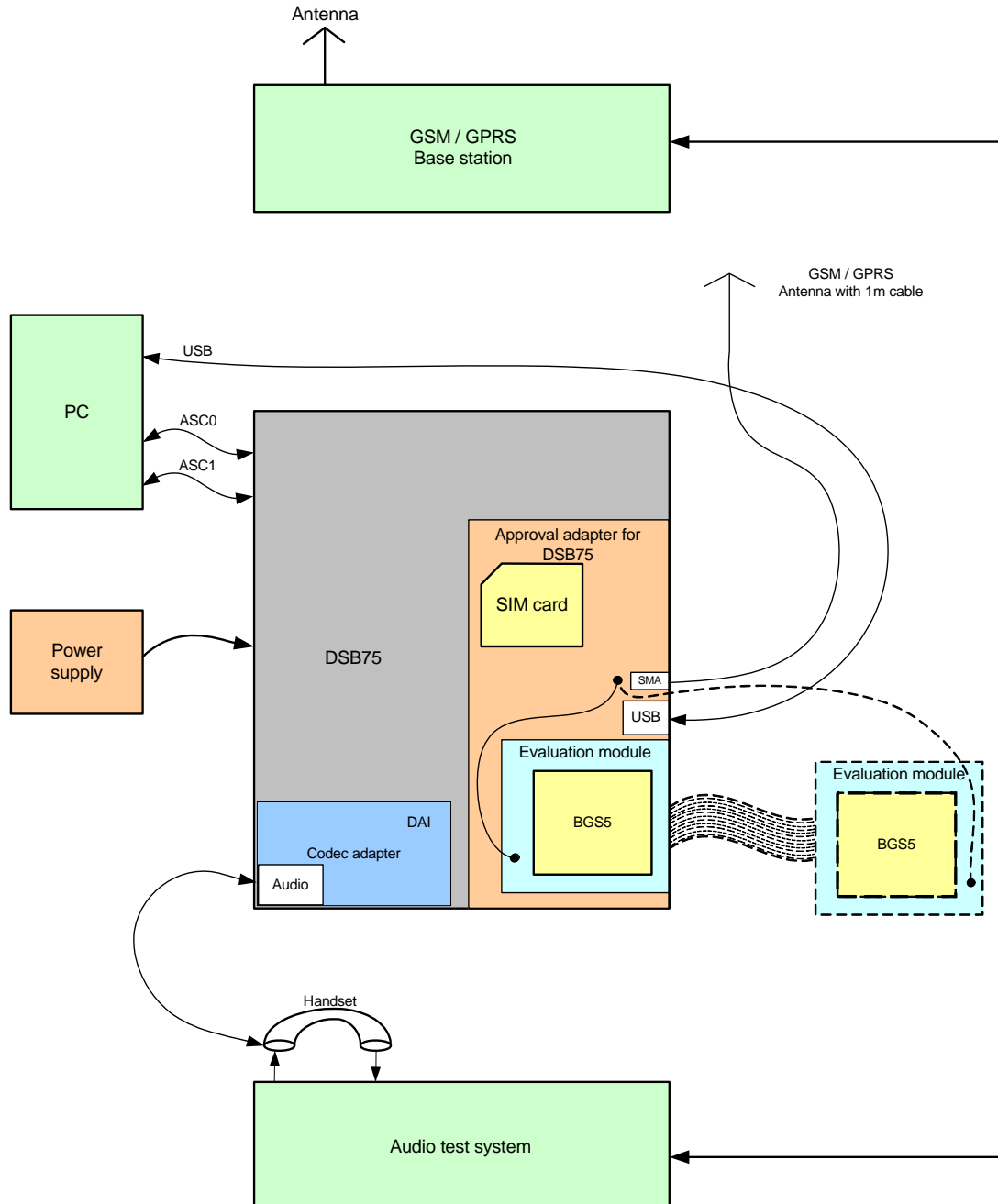

**Figure 54:** Reference equipment for Type Approval

1. For RF performance tests a mini-SMT/U.FL to SMA adapter with attached 6dB coaxial attenuator is chosen to connect the evaluation module directly to the GSM test equipment instead of employing the SMA antenna connectors on the BGS5-DSB75 adapter as shown in Figure 54. The following products are recommended:

Hirose SMA-Jack/U.FL-Plug conversion adapter HRMJ-U.FLP(40)

(for details see <http://www.hirose-connectors.com/> or <http://www.farnell.com/>)

Aeroflex Weinschel Fixed Coaxial Attenuator Model 3T/4T

(for details see <http://www.aeroflex.com/ams/weinschel/pdfs/wmod3&4T.pdf>)

## 5.4 Compliance with FCC and IC Rules and Regulations

The Equipment Authorization Certification for the Gemalto M2M reference application described in [Section 5.3](#) will be registered under the following identifiers:

*FCC Identifier: QIPBGS5*

*Industry Canada Certification Number: 7830A-BGS5*

*Granted to Gemalto M2M GmbH*

Manufacturers of mobile or fixed devices incorporating BGS5 modules are authorized to use the FCC Grants and Industry Canada Certificates of the BGS5 modules for their own final products according to the conditions referenced in these documents. In this case, an FCC/ IC label of the module shall be visible from the outside, or the host device shall bear a second label stating "Contains FCC ID QIPBGS5", and accordingly "Contains IC 7830A-BGS5". The integration is limited to fixed or mobile categorised host devices, where a separation distance between the antenna and any person of min. 20cm can be assured during normal operating conditions. For mobile and fixed operation configurations the antenna gain, including cable loss, must not exceed the limits 2.15 dBi (850 MHz) and 2.15 dBi (1900 MHz).

### IMPORTANT:

Manufacturers of portable applications incorporating BGS5 modules are required to have their final product certified and apply for their own FCC Grant and Industry Canada Certificate related to the specific portable mobile. This is mandatory to meet the SAR requirements for portable mobiles (see [Section 5.2](#) for detail).

Changes or modifications not expressly approved by the party responsible for compliance could void the user's authority to operate the equipment.

**Note:** This equipment has been tested and found to comply with the limits for a Class B digital device, pursuant to part 15 of the FCC Rules and with Industry Canada licence-exempt RSS standard(s). These limits are designed to provide reasonable protection against harmful interference in a residential installation. This equipment generates, uses and can radiate radio frequency energy and, if not installed and used in accordance with the instructions, may cause harmful interference to radio communications. However, there is no guarantee that interference will not occur in a particular installation. If this equipment does cause harmful interference to radio or television reception, which can be determined by turning the equipment off and on, the user is encouraged to try to correct the interference by one or more of the following measures:

- Reorient or relocate the receiving antenna.
- Increase the separation between the equipment and receiver.
- Connect the equipment into an outlet on a circuit different from that to which the receiver is connected.
- Consult the dealer or an experienced radio/TV technician for help.

This Class B digital apparatus complies with Canadian ICES-003.

If Canadian approval is requested for devices incorporating BGS5 modules the above note will have to be provided in the English and French language in the final user documentation. Manufacturers/OEM Integrators must ensure that the final user documentation does not contain any information on how to install or remove the module from the final product.



## 6 Document Information

### 6.1 Revision History

Preceding document: "BGS5 Hardware Interface Description" Version 00.290a

New document: "BGS5 Hardware Interface Description" Version **01.100**

Chapter	What is new
1.1	Added implementation details for frequency bands.
1.3	Revised <a href="#">Figure 2</a> .
2.1.1	Revised pad 245 (Do not use --> GND).
2.1.2	Revised ratings for VCORE. Added resolution and tolerance to ADC signal properties. Updated ratings for RTC backup, USB and ASC0. Added remark that EMERG_RST line must always be connected to V180 with a 2.2KOhm pull-up resistor. Also adapted sample application ( <a href="#">Figure 26</a> ) and <a href="#">Section 3.2.2.2</a> accordingly.
2.1.2.1	Added <a href="#">Table 4</a> to list absolute maximum ratings for internal GSM power amplifier.
2.1.7	Updated name of sample external codec that may be used with PCM functionality.
2.1.9	Removed note on GPIO high-impedance state after module startup. Revised alternative signal assignment for GPIO1...3.
2.1.10	Revised section to include AT configuration command.
2.1.11	Completed section <a href="#">SPI Interface</a> .
2.2.1	Completed <a href="#">Table 10</a> .
2.3.1	New section <a href="#">Sample Level Conversion Circuit</a> .
3.2.4.2	New section <a href="#">Disconnect BGS5 BATT+ Lines</a> .
3.2.3	Revised some signal states for first startup configuration.
3.2.5	Removed mention of over- and undervoltage shutdown.
3.4	Updated power supply ratings listed in <a href="#">Table 14</a> .
4.2	Added note regarding routing of signal tracks.
4.2.1.1	Revised stencils shown in <a href="#">Figure 41</a> and <a href="#">Figure 42</a> .
5.4	Revised antenna gain limits.

Preceding document: "BGS5 Hardware Interface Description" Version 00.290

New document: "BGS5 Hardware Interface Description" Version 00.290a

Chapter	What is new
3.4	Updated power supply ratings listed in <a href="#">Table 14</a> . Also adapted I for BATT+ in <a href="#">Table 2</a> .

## 6.2 Related Documents

Preceding document: "BGS5 Hardware Interface Description" Version 00.001

New document: "BGS5 Hardware Interface Description" Version 00.290

Chapter	What is new
<a href="#">2.1.3</a> , <a href="#">3.3</a>	Added notes regarding USB interface, SLEEP mode and power saving.

New document: "BGS5 Hardware Interface Description" Version 00.001

Chapter	What is new
--	Initial document setup.

## 6.2 Related Documents

- [1] BGS5 AT Command Set
- [2] BGS5 Release Note
- [3] Application Note 48: SMT Module Integration

## 6.3 Terms and Abbreviations

Abbreviation	Description
ADC	Analog-to-digital converter
AGC	Automatic Gain Control
ANSI	American National Standards Institute
ARFCN	Absolute Radio Frequency Channel Number
ARP	Antenna Reference Point
ASC0/ASC1	Asynchronous Controller. Abbreviations used for first and second serial interface of BGS5
B	Thermistor Constant
BER	Bit Error Rate
BTS	Base Transceiver Station
CB or CBM	Cell Broadcast Message
CE	Conformité Européene (European Conformity)
CHAP	Challenge Handshake Authentication Protocol
CPU	Central Processing Unit
CS	Coding Scheme
CSD	Circuit Switched Data
CTS	Clear to Send

## 6.3 Terms and Abbreviations

Abbreviation	Description
DAC	Digital-to-Analog Converter
DAI	Digital Audio Interface
dBm0	Digital level, 3.14dBm0 corresponds to full scale, see ITU G.711, A-law
DCE	Data Communication Equipment (typically modems, e.g. Gemalto M2M module)
DCS 1800	Digital Cellular System, also referred to as PCN
DRX	Discontinuous Reception
DSB	Development Support Box
DSP	Digital Signal Processor
DSR	Data Set Ready
DTE	Data Terminal Equipment (typically computer, terminal, printer or, for example, GSM application)
DTR	Data Terminal Ready
DTX	Discontinuous Transmission
EFR	Enhanced Full Rate
EGSM	Enhanced GSM
EIRP	Equivalent Isotropic Radiated Power
EMC	Electromagnetic Compatibility
ERP	Effective Radiated Power
ESD	Electrostatic Discharge
ETS	European Telecommunication Standard
FCC	Federal Communications Commission (U.S.)
FDMA	Frequency Division Multiple Access
FR	Full Rate
GPIO	General Purpose Input/Output
GPRS	General Packet Radio Service
GSM	Global Standard for Mobile Communications
HiZ	High Impedance
HR	Half Rate
I/O	Input/Output
IC	Integrated Circuit
IMEI	International Mobile Equipment Identity
ISO	International Standards Organization
ITU	International Telecommunications Union
kbps	kbits per second
LED	Light Emitting Diode
Li-Ion/Li+	Lithium-Ion
Li battery	Rechargeable Lithium Ion or Lithium Polymer battery
Mbps	Mbits per second

## 6.3 Terms and Abbreviations

Abbreviation	Description
MMI	Man Machine Interface
MO	Mobile Originated
MS	Mobile Station (GSM module), also referred to as TE
MSISDN	Mobile Station International ISDN number
MT	Mobile Terminated
NTC	Negative Temperature Coefficient
OEM	Original Equipment Manufacturer
PA	Power Amplifier
PAP	Password Authentication Protocol
PBCCH	Packet Switched Broadcast Control Channel
PCB	Printed Circuit Board
PCL	Power Control Level
PCM	Pulse Code Modulation
PCN	Personal Communications Network, also referred to as DCS 1800
PCS	Personal Communication System, also referred to as GSM 1900
PDU	Protocol Data Unit
PLL	Phase Locked Loop
PPP	Point-to-point protocol
PSU	Power Supply Unit
PWM	Pulse Width Modulation
R&TTE	Radio and Telecommunication Terminal Equipment
RAM	Random Access Memory
RF	Radio Frequency
RLS	Radio Link Stability
RMS	Root Mean Square (value)
RoHS	Restriction of the use of certain hazardous substances in electrical and electronic equipment.
ROM	Read-only Memory
RTC	Real Time Clock
RTS	Request to Send
Rx	Receive Direction
SAR	Specific Absorption Rate
SAW	Surface Accoustic Wave
SELV	Safety Extra Low Voltage
SIM	Subscriber Identification Module
SMD	Surface Mount Device
SMS	Short Message Service
SMT	Surface Mount Technology







## 6.3 Terms and Abbreviations

---

Abbreviation	Description
SRAM	Static Random Access Memory
TA	Terminal adapter (e.g. GSM module)
TDMA	Time Division Multiple Access
TE	Terminal Equipment, also referred to as DTE
TLS	Transport Layer Security
Tx	Transmit Direction
UART	Universal asynchronous receiver-transmitter
URC	Unsolicited Result Code
USSD	Unstructured Supplementary Service Data

## 6.4 Safety Precaution Notes

The following safety precautions must be observed during all phases of the operation, usage, service or repair of any cellular terminal or mobile incorporating BGS5. Manufacturers of the cellular terminal are advised to convey the following safety information to users and operating personnel and to incorporate these guidelines into all manuals supplied with the product. Failure to comply with these precautions violates safety standards of design, manufacture and intended use of the product. Gemalto M2M assumes no liability for customer's failure to comply with these precautions.

	<p>When in a hospital or other health care facility, observe the restrictions on the use of mobiles. Switch the cellular terminal or mobile off, if instructed to do so by the guidelines posted in sensitive areas. Medical equipment may be sensitive to RF energy. The operation of cardiac pacemakers, other implanted medical equipment and hearing aids can be affected by interference from cellular terminals or mobiles placed close to the device. If in doubt about potential danger, contact the physician or the manufacturer of the device to verify that the equipment is properly shielded. Pacemaker patients are advised to keep their hand-held mobile away from the pacemaker, while it is on.</p>
	<p>Switch off the cellular terminal or mobile before boarding an aircraft. Make sure it cannot be switched on inadvertently. The operation of wireless appliances in an aircraft is forbidden to prevent interference with communications systems. Failure to observe these instructions may lead to the suspension or denial of cellular services to the offender, legal action, or both.</p>
	<p>Do not operate the cellular terminal or mobile in the presence of flammable gases or fumes. Switch off the cellular terminal when you are near petrol stations, fuel depots, chemical plants or where blasting operations are in progress. Operation of any electrical equipment in potentially explosive atmospheres can constitute a safety hazard.</p>
	<p>Your cellular terminal or mobile receives and transmits radio frequency energy while switched on. Remember that interference can occur if it is used close to TV sets, radios, computers or inadequately shielded equipment. Follow any special regulations and always switch off the cellular terminal or mobile wherever forbidden, or when you suspect that it may cause interference or danger.</p>
	<p>Road safety comes first! Do not use a hand-held cellular terminal or mobile when driving a vehicle, unless it is securely mounted in a holder for speakerphone operation. Before making a call with a hand-held terminal or mobile, park the vehicle. Speakerphones must be installed by qualified personnel. Faulty installation or operation can constitute a safety hazard.</p>
	<p><b>IMPORTANT!</b> Cellular terminals or mobiles operate using radio signals and cellular networks. Because of this, connection cannot be guaranteed at all times under all conditions. Therefore, you should never rely solely upon any wireless device for essential communications, for example emergency calls. Remember, in order to make or receive calls, the cellular terminal or mobile must be switched on and in a service area with adequate cellular signal strength. Some networks do not allow for emergency calls if certain network services or phone features are in use (e.g. lock functions, fixed dialing etc.). You may need to deactivate those features before you can make an emergency call. Some networks require that a valid SIM card be properly inserted in the cellular terminal or mobile.</p>

## 7 Appendix

### 7.1 List of Parts and Accessories

**Table 28:** List of parts and accessories

Description	Supplier	Ordering information
BGS5	Gemalto M2M	Standard module Gemalto M2M IMEI: Packaging unit (ordering) number: L30960-N3300-A100 (BGS5) Module label number: S30960-S3300-A100-1 (BGS5)
DSB75 Evaluation Kit	Gemalto M2M	Ordering number: L36880-N8811-A100
Multi-Adapter R1 for mounting BGS5 evaluation modules onto DSB75	Gemalto M2M	Ordering number: L30960-N0010-A100
Approval adapter for mounting BGS5 evaluation modules onto DSB75	Gemalto M2M	Ordering number: L30960-N2301-A100
Evaluation Module	Gemalto M2M	Ordering number: L30960-N3301-A100 (BGS5)
Votronic Handset	VOTRONIC / Gemalto M2M	Gemalto M2M ordering number: L36880-N8301-A107 Votronic ordering number: HH-SI-30.3/V1.1/0 VOTRONIC Entwicklungs- und Produktionsgesellschaft für elektronische Geräte mbH Saarbrücker Str. 8 66386 St. Ingbert Germany Phone: +49-(0)6 89 4 / 92 55-0 Fax: +49-(0)6 89 4 / 92 55-88 Email: <a href="mailto:contact@votronic.com">contact@votronic.com</a>
SIM card holder incl. push button ejector and slide-in tray	Molex	Ordering numbers: 91228 91236 Sales contacts are listed in <a href="#">Table 29</a> .

## 7.1 List of Parts and Accessories

**Table 29:** Molex sales contacts (subject to change)

<p>Molex For further information please click: <a href="http://www.molex.com">http://www.molex.com</a></p>	<p>Molex Deutschland GmbH Otto-Hahn-Str. 1b 69190 Walldorf Germany Phone: +49-6227-3091-0 Fax: +49-6227-3091-8100 Email: <a href="mailto:mxgermany@molex.com">mxgermany@molex.com</a></p>	<p>American Headquarters Lisle, Illinois 60532 U.S.A. Phone: +1-800-78MOLEX Fax: +1-630-969-1352</p>
<p>Molex China Distributors Beijing, Room 1311, Tower B, COFCO Plaza No. 8, Jian Guo Men Nei Street, 100005 Beijing P.R. China Phone: +86-10-6526-9628 Fax: +86-10-6526-9730</p>	<p>Molex Singapore Pte. Ltd. 110, International Road Jurong Town, Singapore 629174  Phone: +65-6-268-6868 Fax: +65-6-265-6044</p>	<p>Molex Japan Co. Ltd. 1-5-4 Fukami-Higashi, Yamato-City, Kanagawa, 242-8585 Japan  Phone: +81-46-265-2325 Fax: +81-46-265-2365</p>



## About Gemalto

Gemalto (Euronext NL0000400653 GTO) is the world leader in digital security with 2011 annual revenues of €2 billion and more than 10,000 employees operating out of 74 offices and 14 Research & Development centers, located in 43 countries.

We are at the heart of the rapidly evolving digital society. Billions of people worldwide increasingly want the freedom to communicate, travel, shop, bank, entertain and work - anytime, everywhere - in ways that are enjoyable and safe. Gemalto delivers on their expanding needs for personal mobile services, payment security, authenticated cloud access, identity and privacy protection, eHealthcare and eGovernment efficiency, convenient ticketing and dependable machine-to-machine (M2M) applications.

Gemalto develops secure embedded software and secure products which we design and personalize. Our platforms and services manage these secure products, the confidential data they contain and the trusted end-user services they enable. Our innovations enable our clients to offer trusted and convenient digital services to billions of individuals.

Gemalto thrives with the growing number of people using its solutions to interact with the digital and wireless world.

### For more information please visit

[m2m.gemalto.com](http://m2m.gemalto.com), [www.facebook.com/gemalto](http://www.facebook.com/gemalto), or [Follow@gemaltom2m](https://twitter.com/Follow@gemaltom2m) on twitter.

**Gemalto M2M GmbH**  
St.-Martin-Str. 60  
81541 Munich  
Germany

➔ [M2M.GEMALTO.COM](http://M2M.GEMALTO.COM)

**gemalto**  
security to be free