



**FATEK**

# ***FBs-1HLC***

## **Precision Load Cell Module**

Operation manual

V1.0      06/03/2014

FATEK AUTOMATION CORP.

---

## Contents

|           |                                                                 |    |
|-----------|-----------------------------------------------------------------|----|
| Chapter 1 | 1HLC module introduction.....                                   | 3  |
| 1.1       | Module specification: .....                                     | 3  |
| 1.2       | Module appearance and description.....                          | 4  |
| 1.3       | Application connections.....                                    | 4  |
| 1.4       | Communication interface between 1HLC and PLC:.....              | 6  |
| 1.5       | 1HLC application interface: .....                               | 6  |
| 1.5.1     | Application interface contents and Modbus comparison table..... | 6  |
| 1.5.2     | Detailed description .....                                      | 7  |
| Chapter 2 | Application examples .....                                      | 8  |
| 2.1       | Application connections.....                                    | 8  |
| 2.2       | Setting PLC communication parameters.....                       | 8  |
| 2.3       | Ladder diagram programming.....                                 | 9  |
| 2.4       | 1HLC module calibration.....                                    | 10 |
| 2.4.1     | Zero-point calibration.....                                     | 10 |
| 2.4.2     | Full-span calibration.....                                      | 10 |
| 2.4.3     | Weight measuring .....                                          | 10 |

# Chapter 1 1HLC module introduction

A load cell is formed by attaching a stress strain gauge to a metal elastic body. When the metal elastic body is subjected to pressure or tensile force, the deformation of the elastic body is detected and converted to an output voltage signal. PLC acquires data from 1HLC via the Modbus communication protocol.

## 1.1 Module specification:

| <b>General specification</b>                                                                                                             |                                                                      |
|------------------------------------------------------------------------------------------------------------------------------------------|----------------------------------------------------------------------|
| Supply voltage                                                                                                                           | DC 24V                                                               |
| Weight                                                                                                                                   | 127g                                                                 |
| Operation temperature                                                                                                                    | -10°C to + 40°C (+14°F to + 104°F)                                   |
| Operation humidity                                                                                                                       | 85% relative humidity (non-condensing state)                         |
| Dimensions                                                                                                                               | 90 (L) x 40 (W) x 80 (H) mm                                          |
| <b>Input signal and A/D conversion</b>                                                                                                   |                                                                      |
| A/D conversion method                                                                                                                    | 24Bits $\Delta \Sigma$                                               |
| A/D conversion speed                                                                                                                     | 100 times/sec                                                        |
| Load cell excitation power supply                                                                                                        | DC 5V $\pm 5\%$ , 120mA (for 8 350 $\Omega$ load cells )             |
| Max. measured voltage                                                                                                                    | -1mV ~ 39mV                                                          |
| Input sensitivity/resolution                                                                                                             | Above 0.15 $\mu$ V/D 1 / 60000 d                                     |
| <b>Digital</b>                                                                                                                           |                                                                      |
| Status indicators                                                                                                                        | POWER 、 MD 、 ZERO 、 NET 、 GROSS                                      |
| Memory                                                                                                                                   | Calibration parameters and function settings are all saved to EEPROM |
| <b>Features</b>                                                                                                                          |                                                                      |
| 1. Industrial-grade weight control design suitable for all kinds of extreme industrial environments                                      |                                                                      |
| 2. High noise-interference resistance; effectively suppresses interferences from power supplies, electromagnetic waves, and wireless RF. |                                                                      |
| 3. Small volume and occupies little space; convenient for storage in control stations, high precision, and superior performances         |                                                                      |
| 4. Adjustable digital filtering may effectively suppress vibrations generated in local environment                                       |                                                                      |
| 5. Flexible calibration schemes and automatic stability detection                                                                        |                                                                      |
| 6. Automatic zero-point tracking for effective suppressing of zero-point drift occurring in load cells                                   |                                                                      |

## 1.2 Module appearance and description

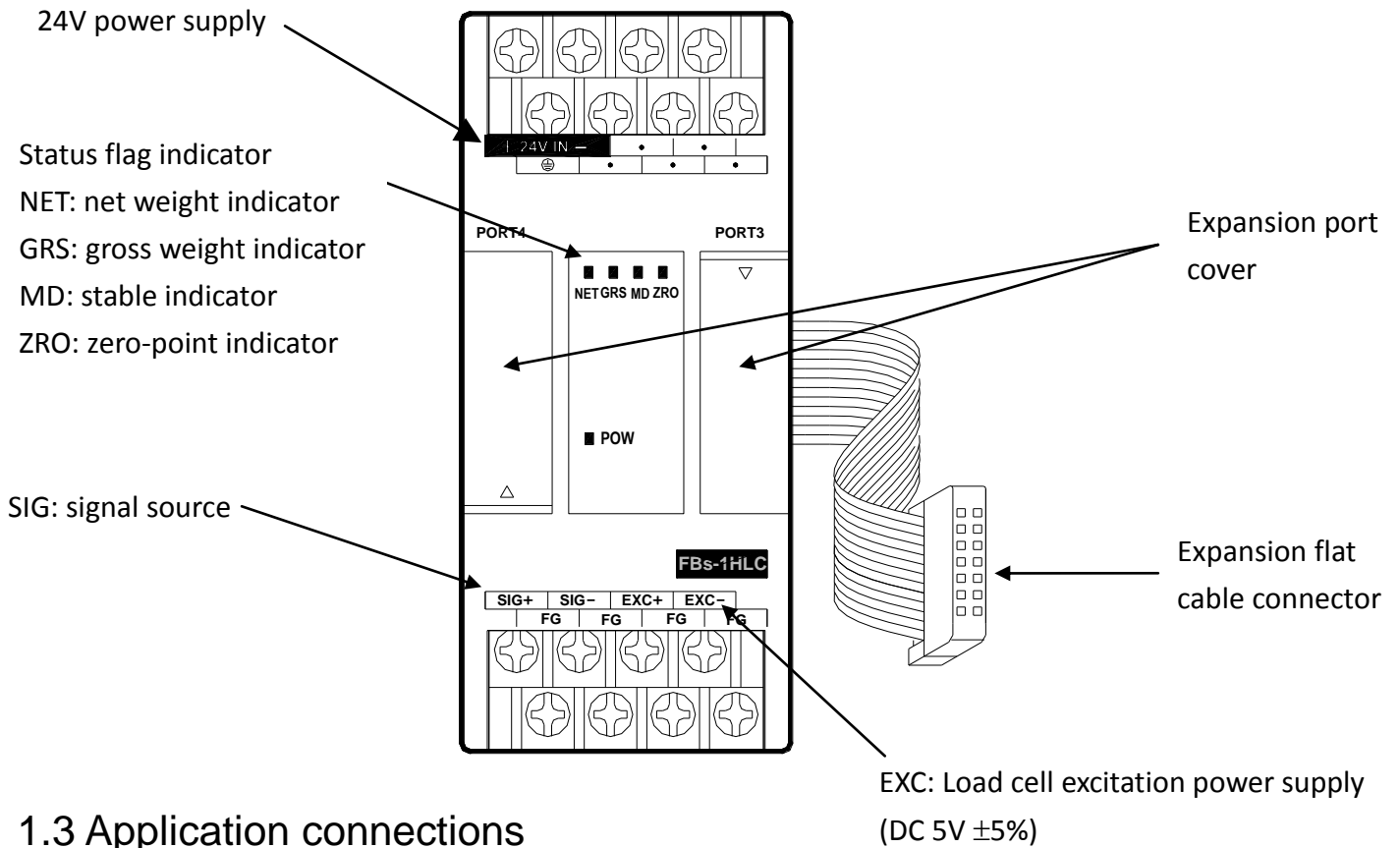

## 1.3 Application connections

### Four-line connection

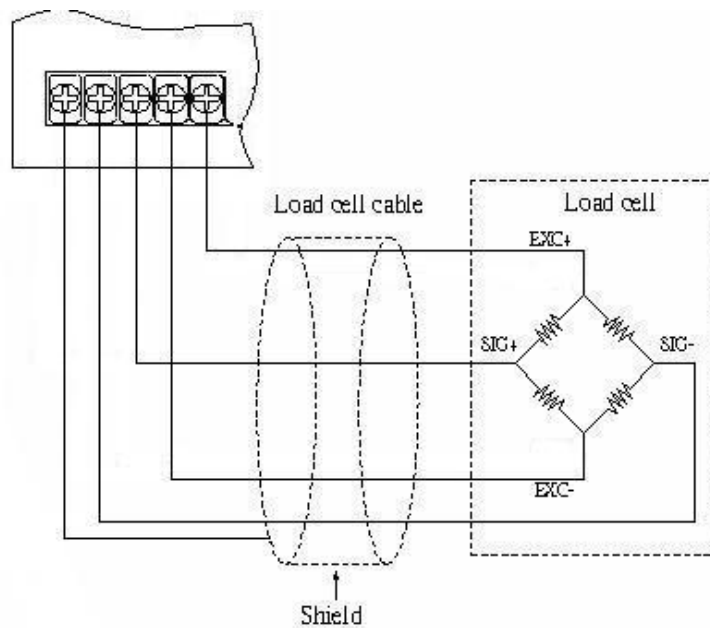

## Six-line connection

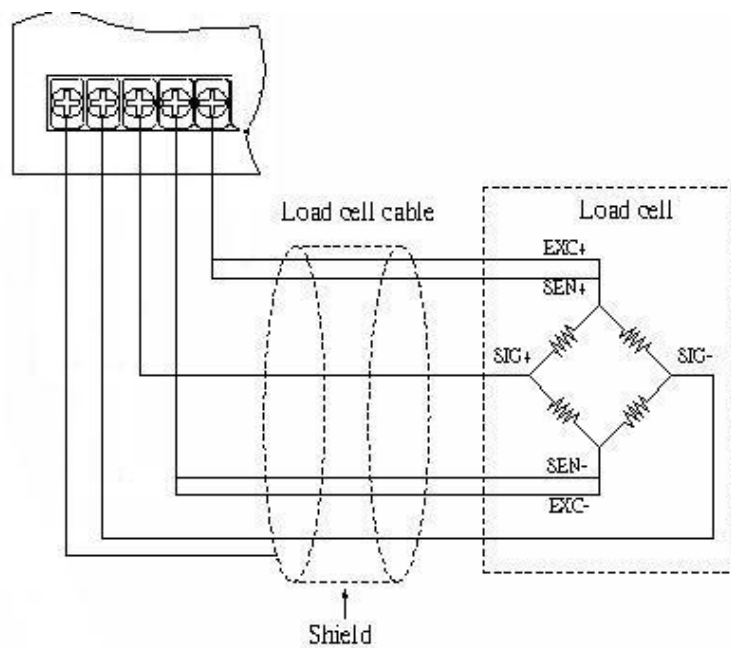

## Multiple-load-cell connection

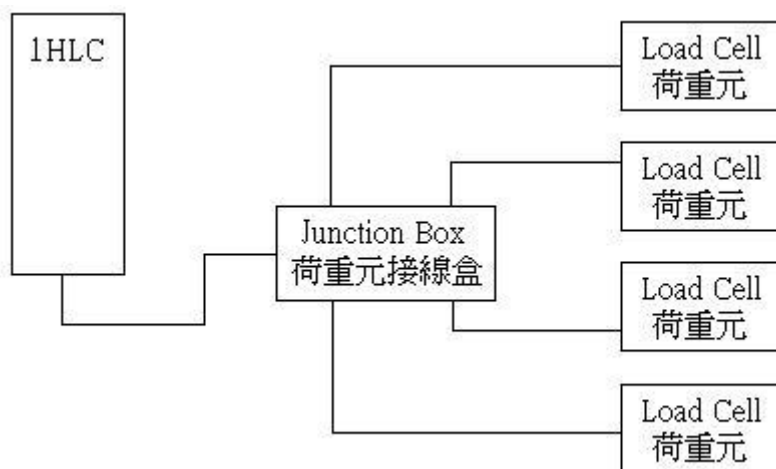

## 1.4 Communication interface between 1HLC and PLC:

PLC acquires data from 1HLC via the Modbus communication protocol.

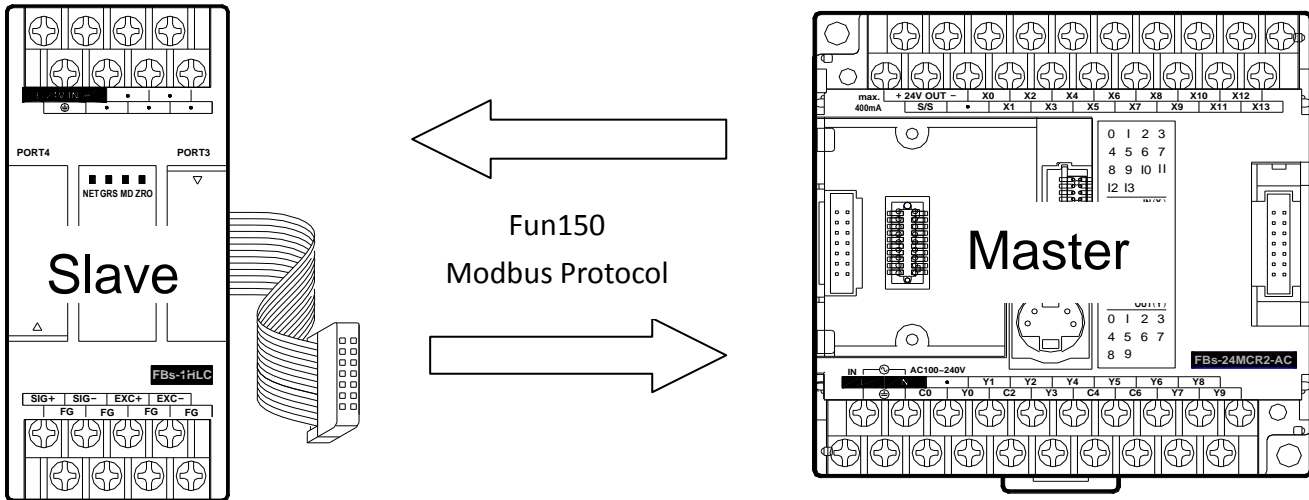

Connect to PLC using Winproladder and change the PORT 3 communication parameters of Winproladder. The communication parameters of 1HLC are fixed as follow:

| PORT  | Connection speed | Parity bit | Data bit | Stop bit | format |
|-------|------------------|------------|----------|----------|--------|
| Port3 | 19200            | No         | 8        | 1        | RTU    |

## 1.5 1HLC application interface:

### 1.5.1 Application interface contents and Modbus comparison table

Status/Control bit

| Address | Name                         | Length | R/W |
|---------|------------------------------|--------|-----|
| 000002  | Overload flag                | Bit    | R   |
| 000005  | Display gross weight flag    | Bit    | R   |
| 000006  | Display net weight flag      | Bit    | R   |
| 000007  | Zero-point flag              | Bit    | R   |
| 000008  | Unstable flag                | Bit    | R   |
| 000257  | Adjust to zero               | Bit    | W   |
| 000258  | Deduction                    | Bit    | W   |
| 000263  | Clear deduction              | Bit    | W   |
| 000513  | Zero-point calibration input | Bit    | W   |
| 000514  | Full-span calibration input  | Bit    | W   |
| 000773  | Save EEP                     | Bit    | W   |

## Status/Settings register

| Address | Name                      | Settings                                | Length | R/W |
|---------|---------------------------|-----------------------------------------|--------|-----|
| 402305  | AD internal value         |                                         | Word   | R   |
| 402307  | Display value             |                                         | 2Word  | R   |
| 402567  | SPAN calibration weight   |                                         | 2Word  | R   |
| 402561  | Max. weight               |                                         | 2Word  | R/W |
| 401793  | Calibration error message | 0~3                                     | Word   | R/W |
| 402049  | AD sampling frequency     | 0=100 · 1=50 · 2=25 · 3=12.5 · 4=6.25Hz | Word   | R/W |
| 402052  | Min. scale                | 1,2,5,10,20,50                          | Word   | R/W |

## 1.5.2 Detailed description

### Status/Control bit

| Address | Name                         | Description                                                                                                          |
|---------|------------------------------|----------------------------------------------------------------------------------------------------------------------|
| 000002  | Overload flag                | Flag ON when the measured weight is higher than the max. weight                                                      |
| 000005  | Display gross weight flag    | Displayed measurement value includes package weight                                                                  |
| 000006  | Display net weight flag      | Displayed measurement value is actual weight                                                                         |
| 000007  | Zero-point flag              | Gross weight is 0 when=1                                                                                             |
| 000008  | Unstable flag                | Conditions of unstable tracking time and unstable tracking area may be set for the devices maintaining stable values |
| 000257  | Adjust to zero               | Function to set or adjust the displayed value to zero when there is no load when=1                                   |
| 000258  | Deduction                    | Deduce the package weight of the load on the tray when=1                                                             |
| 000263  | Clear deduction              | Clear the package weight deduction and display gross weight when=1                                                   |
| 000513  | Zero-point calibration input | Zero-point button to be set during calibration when=1                                                                |
| 000514  | Full-span calibration input  | SPAN weight button to be set during calibration when=1 (SPAN calibration weight should be set first)                 |
| 000773  | Save EEP                     | Save settings in EEPROM and automatically read previously saved settings at power-on when=1                          |

## Status/Settings register

| Address | Name                      | Description                                                                                                                                                              |
|---------|---------------------------|--------------------------------------------------------------------------------------------------------------------------------------------------------------------------|
| 402305  | AD internal value         | Value of scale analog signal voltage converted for internal calculations of the scale.                                                                                   |
| 402307  | Display value             | Actual measured weight after specification calibration and weight calibration.                                                                                           |
| 402567  | SPAN calibration weight   | Weight of known standardized weight in calibration.                                                                                                                      |
| 402561  | Max. weight               | Set maximum weight of scale and display overload flag if exceeding the max. weight.                                                                                      |
| 401793  | Calibration error message | 0 : normal<br>1 : AD abnormal<br>2 : weight calibration earlier than prerequisite calibration (e.g., SPAN1<ZERO)<br>3 : weight calibration precision higher than 0.1uV/D |

## Chapter 2 Application examples

### 2.1 Application connections

Complete the hardware wiring connection first; please refer to the hardware equipment and connection scheme in below.

Hardware: FBs-24MC\*1, FBs-1HLC\*1, and scale\*1

1. Connect 1HLC cable to the left (communication) expansion port of PLC.
2. The 4 lines of the scale are connected to EXC+, EXC-, SIG+, and SIG- of 1HLC.

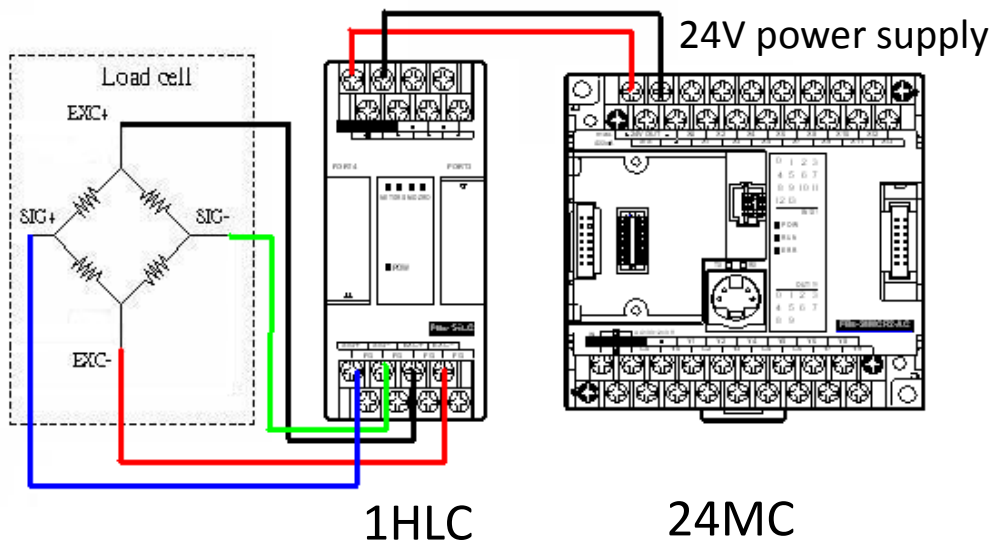

### 2.2 Setting PLC communication parameters

Connect to PLC using Winproladder (24MC in this example) and change the PORT 3 communication



parameters of Winproladder. The communication parameters of 1HLC are fixed as follow:

|       |                  |            |          |          |        |
|-------|------------------|------------|----------|----------|--------|
| PORT  | Connection speed | Parity bit | Data bit | Stop bit | format |
| Port3 | 19200            | No         | 8        | 1        | RTU    |

## 2.3 Ladder diagram programming

1. Establish FUN150 in the ladder diagram of Winproladder and use FUN150 Modbus to transmit data from 1HLC.

Use X0 to control M102 and X1 to control M103 because M102 is the zero-point calibration control coil (000513) and M103 is the full-span calibration control coil (000514) from the Modbus Master table in step 2.

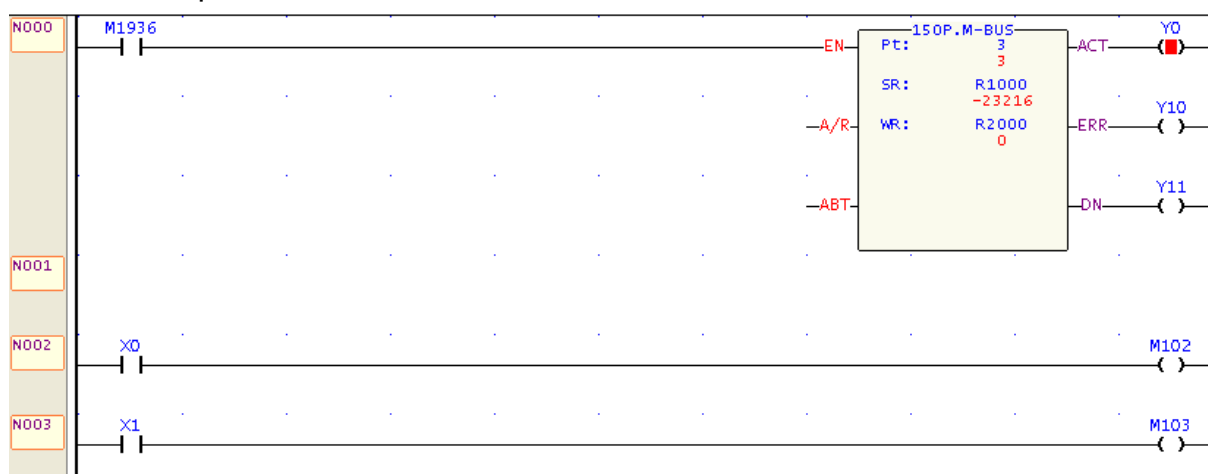

2. Register addresses to be read or written are set in the Modbus Master table; for the register addresses of the slave please refer to **【1.5.1 Application interface contents and Modbus comparison table】**.

| 筆數 | 命令          | 僕站 | 主站資料 | 僕站資料 | 長度     |   |
|----|-------------|----|------|------|--------|---|
| 0  | 讀取(Read)    | 1  | R500 | <    | 402307 | 2 |
| 1  | 單個寫入(write) | 1  | M100 | >    | 000257 | 1 |
| 2  | 單個寫入(write) | 1  | M101 | >    | 000258 | 1 |
| 3  | 單個寫入(write) | 1  | M102 | >    | 000513 | 1 |
| 4  | 單個寫入(write) | 1  | M103 | >    | 000514 | 1 |
| 5  | 單個寫入(write) | 1  | M104 | >    | 000263 | 1 |
| 6  | 讀取(Read)    | 1  | M105 | <    | 000005 | 1 |
| 7  | 讀取(Read)    | 1  | M106 | <    | 000006 | 1 |
| 8  | 讀取(Read)    | 1  | M107 | <    | 000007 | 1 |
| 9  | 讀取(Read)    | 1  | M108 | <    | 000008 | 1 |
| 10 | 寫入(write)   | 1  | R502 | >    | 402561 | 2 |
| 11 | 寫入(write)   | 1  | R504 | >    | 402567 | 2 |
| 12 | 讀取(Read)    | 1  | R506 | <    | 401793 | 1 |
| 13 | 讀取(Read)    | 1  | R508 | <    | 402305 | 2 |

設定: 動態配置[2840]字組    資料長度: 101 字組    配置位置: R1000-R1100

確定    取消

## 2.4 1HLC module calibration

Module calibration allows the subsequently measured values to be more precise. The registers and connections in the calibration steps have already been converted by step 2 【Modbus Master Table】 in section 2.3 and the detailed corresponding registers are described in this section.

### 2.4.1 Zero-point calibration

Confirm that the tray or tank scale is empty and execute zero-point calibration input (X0 from 0 to 1); if successful, the display value register DR500 (Modbus register 402307) will be zero. If not, confirm whether the zero-point calibration operation is correct. Subsequently, set the status of X0 of zero-point calibration back to 0 or else the display value will remain at 0 when measuring.

### 2.4.2 Full-span calibration

Place object of known weight (standardized weight) on the tray or tank scale and input the weight of the object of known weight to the SPAN calibration weight register DR504 (Modbus register 402567); after the displayed value is stable, execute SPAN calibration input (X1 from 0 to 1). The display value register DR500 (Modbus register 402307) will be the same as DR504 (Modbus register 402567). Subsequently, set X1 from 1 to 0 and remove the object of known weight (standardized weight); measurements of objects may then begin.

Note: if register DR504 (Modbus register 402567) is zero then the display value register DR500 (Modbus register 402307) will remain zero when measuring weights.

### 2.4.3 Weight measuring

Place object on the tray and the display value register DR500 (Modbus register 402307) will display the weight of the object according to the standard of the known weight in full-span calibration.